

NATURE OF DISCHARGE REPORT

Submarine Emergency Diesel Engine Wet Exhaust

1.0 INTRODUCTION

The National Defense Authorization Act of 1996 amended Section 312 of the Federal Water Pollution Control Act (also known as the Clean Water Act (CWA)) to require that the Secretary of Defense and the Administrator of the Environmental Protection Agency (EPA) develop uniform national discharge standards (UNDS) for vessels of the Armed Forces for “...discharges, other than sewage, incidental to normal operation of a vessel of the Armed Forces, ...” [Section 312(n)(1)]. UNDS is being developed in three phases. The first phase (which this report supports), will determine which discharges will be required to be controlled by marine pollution control devices (MPCDs)—either equipment or management practices. The second phase will develop MPCD performance standards. The final phase will determine the design, construction, installation, and use of MPCDs.

A nature of discharge (NOD) report has been prepared for each of the discharges that has been identified as a candidate for regulation under UNDS. The NOD reports were developed based on information obtained from the technical community within the Navy and other branches of the Armed Forces with vessels potentially subject to UNDS, from information available in existing technical reports and documentation, and, when required, from data obtained from discharge samples that were collected under the UNDS program.

The purpose of the NOD report is to describe the discharge in detail, including the system that produces the discharge, the equipment involved, the constituents released to the environment, and the current practice, if any, to prevent or minimize environmental effects. Where existing process information is insufficient to characterize the discharge, the NOD report provides the results of additional sampling or other data gathered on the discharge. Based on the above information, the NOD report describes how the estimated constituent concentrations and mass loading to the environment were determined. Finally, the NOD report assesses the potential for environmental effect. The NOD report contains sections on: Discharge Description, Discharge Characteristics, Nature of Discharge Analysis, Conclusions, and Data Sources and References.

2.0 DISCHARGE DESCRIPTION

This section describes the submarine emergency diesel engine wet exhaust liquid discharge and includes information on: the equipment that is used and its operation (Section 2.1), general description of the constituents of the discharge (Section 2.2), and the vessels that produce this discharge (Section 2.3).

2.1 Equipment Description and Operation

All submarines have emergency diesel engines for use during emergency situations, such as providing electric power or emergency ventilation. However, emergency diesel engines are routinely used during training exercises, pre-underway checks, and quarterly performance analyses. All submarines have air induction and diesel exhaust systems for emergency diesel engines. Air induction systems bring in outside air for combustion in the emergency diesel engines, while exhaust systems discharge the combustion by-products overboard. Prior to discharge, the exhaust gases are cooled by seawater injection into the exhaust. Water is injected to reduce radiant energy from the exhaust piping and to reduce corrosion of the exhaust piping from high temperatures.

Each submarine is equipped with one emergency diesel engine. Refer to Figure 1 and Figure 2 for a representation of the wet exhaust system.

2.2 Releases to the Environment

The exhaust-water mixture is vented from the exhaust stack into the atmosphere. Some of the water mist with entrained or dissolved exhaust products will settle into the seawater surrounding the exhaust stack. For the purposes of this analysis, it is assumed that all of the discharge settles to the water's surface.

2.3 Vessels Producing the Discharge

The Navy is the only branch of the Armed Forces that operates submarines. All active submarines in the fleet produce this discharge. For this report, information on the discharge rates from the three main submarine classes was used, representing 86 of the 89 active submarines. The classes of submarines producing emergency diesel wet exhaust discharge analyzed in this report are summarized in Table 1.

3.0 DISCHARGE CHARACTERISTICS

This section contains qualitative and quantitative information that characterizes the discharge. Section 3.1 describes where the discharge occurs with respect to harbors and near-shore areas, Section 3.2 describes the rate of the discharge, Section 3.3 lists the constituents in the discharge, and Section 3.4 gives the concentrations of the constituents in the discharge.

3.1 Locality

Each vessel operates the emergency diesel engine an average of 60 hours annually within 12 n.m. of shore.

3.2 Rate

Table 1 provides discharge rates for individual classes of submarines. Discharge rates vary for each vessel class, from approximately 7 gallons per minute (gpm) to 15 gpm, and are dependent on the water injection rate into the exhaust system.^{1,2,3,4} For this analysis, it was assumed that all of the water injected into the exhaust system is eventually discharged to the receiving water body. This represents an overestimate for total flow volumes, because much of the injected seawater has the potential to vaporize.

3.3 Constituents

Constituents of exhaust from diesel engines include both organic and inorganic substances. These substances originate primarily from the diesel fuel and also from engine lubricants. Most of the substances that originate from the diesel fuel are products of combustion. Some diesel fuel can pass through the engine unburned, along with combustion products in the exhaust.⁵

Inorganic substances in diesel exhaust include combustion products such as carbon dioxide (CO₂), carbon monoxide (CO), oxides of nitrogen (NO_x), oxides of sulfur (SO_x), and metals. The specific substances and their concentrations in the exhaust depend on a number of factors, including the composition of the fuel, engine temperature, engine use, and engine condition. Many of the organic substances in diesel exhaust condense into particulates, that is, the oily soot visible in the exhaust.⁶

Standard air emissions factors for large stationary diesel industrial engines were used to study the constituents in this discharge. EPA has published emission factors for large stationary diesel engines 600 hp and over. These emissions factors relate quantities of released materials to fuel input, as nanograms per Joule (ng/J), or as power output, as in grams per horsepower-hour (g/hp-hr). Although intended for stationary industrial diesel engines, these emission factors can be used to approximate emergency diesel engine emissions.⁶

Table 2 lists the emission factors for constituents present in the air exhaust of large diesel engines.⁶ As the cooling water is injected into the air exhaust, many of these constituents have the potential to be introduced into the water. Of the compounds shown in Table 2, benzene, toluene, acrolein, naphthalene, acenaphthylene, acenaphthene, fluorene, phenanthrene, anthracene, fluoranthene, pyrene, benzo(a)anthracene, chrysene, benzo(b)fluoranthene, benzo(k)fluoranthene, benzo(a)pyrene, indeno(1,2,3-cd)pyrene, dibenzo(a,h)anthracene, and benzo(g,h,i)perylene are priority pollutants. This discharge is not expected to contain bioaccumulators.

3.4 Concentrations

Using submarine diesel engine power output specifications, the concentrations of the chemical constituents in the engine exhaust were estimated for each submarine class. By making the assumption that all constituents in the discharge liquid resulted from exhaust gases dissolving in the cooling water under equilibrium conditions, it is possible to estimate the concentration of constituents in the liquid using Henry's Law. Henry's Law describes the solubility of gases in a liquid and relates the concentration of a constituent in a liquid to the partial pressure of the constituent in the gaseous phase surrounding the liquid. The calculation sheet at the end of this report presents the assumptions made for this approach and provides a sample calculation for the concentration of benzene in the wet exhaust of a SSN 688 class submarine. Estimated concentrations are presented in Table 3.

4.0 NATURE OF DISCHARGE ANALYSIS

Based on the discharge characteristics presented in Section 3.0, the nature of the discharge and its potential impact on the environment can be evaluated. The estimated mass loadings are presented in Section 4.1. In Section 4.2, the concentrations of discharge constituents after release to the environment are estimated and compared with water quality criteria. In Section 4.3, the potential for the transfer of non-indigenous species is discussed.

4.1 Mass Loadings

Mass loadings were calculated for constituents that exceed WQC using annual flow volumes (Table 1) and estimated constituent concentrations (Table 3). Annual flow volumes were calculated using the cooling water injection rate (Table 1) and an average operational time of 60 hours annually within 12 n.m. of shore, per submarine.¹ Fleet-wide mass loadings for individual chemical constituents were calculated through the following equation and are shown in Table 4.

$\begin{aligned} \text{Annual Mass Loading (kg)} \\ = (\text{Concentration in Discharge (mg/L)})(\text{Annual Discharge (gal)})(3.785 \text{ L/gal})(10^{-6} \text{ kg/mg}) \end{aligned}$
--

The mass loading calculations are an overestimate. Calculations using Henry's Law assumed that equilibrium conditions exist. However, due to the low residence time (<1 second) of both exhaust products and water in the wet exhaust system, equilibrium conditions are unlikely.⁷ Therefore, constituent concentrations are expected to be lower than calculated.

4.2 Environmental Concentrations

A comparison of estimated constituent concentrations to corresponding Federal and most stringent state water quality criteria (WQC) is presented in Table 5. The estimated concentrations of phenanthrene, benzo(a)anthracene, chrysene, indeno(1,2,3-cd)pyrene, dibenzo(ah)anthracene, and benzo(g,h,i)perylene individually exceed the most stringent state (Florida) WQC. Concentrations have been based on a water temperature of 60°F. Since the majority of

submarines are located in warm water ports, it is believed that 60°F is a reasonable assumption for an average water temperature. Concentrations may increase at colder temperatures because of increased constituent solubilities. However, even if concentrations triple, none of the individual constituents will exceed federal water quality criteria and only one additional individual compound (benzo(a)pyrene) will exceed Florida criteria for total PAHs. All other constituent concentrations are below relevant WQC.

4.3 Potential for Introducing Non-Indigenous Species

Because water intake and discharge occur at the same location, there is no significant threat of non-indigenous species introduction to receiving waters.

5.0 CONCLUSION

This analysis concluded that submarine emergency diesel engine wet exhaust has a low potential for adverse environmental effect. Although total PAHs (the total of the following individual PAH compounds: acenaphthylene, benzo-(a)anthracene, benzo(a)pyrene, benzo(b)fluoranthene, benzo(g,h,i)perylene, benzo(k)fluoranthene, chrysene, dibenzo(a,h)anthracene, indeno(1,2,3-cd)pyrene, and phenanthrene) exceeded water quality criteria for the most stringent state (Florida), the annual Fleet-wide mass loading was only 0.056 pounds from 86 vessels.

6.0 DATA SOURCES AND REFERENCES

To characterize this discharge, information from various sources was obtained. Table 6 shows the sources of data used to develop this NOD report.

Specific References

1. UNDS Data Call Package Submission from COMSUBLANT, 688 & 726 Class Submarine. December 13, 1996.
2. Gerry Viers, Newport News Shipbuilding. Submarine Diesel Exhaust System, 5 February 1997, Doug Hamm, Malcolm Pirnie, Inc.
3. Perry Buckberg, NAVSEA 03X33. Submarine Diesel Exhaust Temperatures, 13 November 1997, Russ Hrabe, M. Rosenblatt & Son, Inc.
4. UNDS Equipment Expert Meeting - Submarine Emergency Diesel Engine Exhaust. 3 September 1996.

5. Faulkner, M.G.; E.B. Dismukes; and J.R. McDonald. Assessment of Diesel Particulate Control: Filters, Scrubbers, and Precipitators. U.S. Environmental Protection Agency. EPA-600/7-79-232a. October, 1979.
6. United States Environmental Protection Agency Office of Air Quality Planning and Standards. Compilation of Air Pollution Emission Factors. AP-42, Fifth Addition, November, 1996.
7. Doug Hamm (MPI). Interoffice Memo: Estimation of Residence Time. March 4, 1998.

General References

USEPA. Toxics Criteria for Those States Not Complying with Clean Water Act Section 303(c)(2)(B). 40 CFR Part 131.36.

USEPA. Interim Final Rule. Water Quality Standards; Establishment of Numeric Criteria for Priority Toxic Pollutants; States' Compliance – Revision of Metals Criteria. 60 FR 22230. May 4, 1995.

USEPA. Water Quality Standards; Establishment of Numeric Criteria for Priority Toxic Pollutants. 57 FR 60848. December 22, 1992.

USEPA. Water Quality Standards; Establishment of Numeric Criteria for Priority Toxic Pollutants for the State of California, Proposed Rule under 40 CFR Part 131, Federal Register, Vol. 62, Number 150. August 5, 1997.

Connecticut. Department of Environmental Protection. Water Quality Standards. Surface Water Quality Standards Effective April 8, 1997.

Florida. Department of Environmental Protection. Surface Water Quality Standards, Chapter 62-302. Effective December 26, 1996.

Georgia Final Regulations. Chapter 391-3-6, Water Quality Control, as provided by The Bureau of National Affairs, Inc., 1996.

Hawaii. Hawaiian Water Quality Standards. Section 11, Chapter 54 of the State Code.

Mississippi. Water Quality Criteria for Intrastate, Interstate and Coastal Waters. Mississippi Department of Environmental Quality, Office of Pollution Control. Adopted November 16, 1995.

New Jersey Final Regulations. Surface Water Quality Standards, Section 7:9B-1, as provided by The Bureau of National Affairs, Inc., 1996.

Texas. Texas Surface Water Quality Standards, Sections 307.2 - 307.10. Texas Natural Resource Conservation Commission. Effective July 13, 1995.

Virginia. Water Quality Standards. Chapter 260, Virginia Administrative Code (VAC) , 9 VAC 25-260.

Washington. Water Quality Standards for Surface Waters of the State of Washington. Chapter 173-201A, Washington Administrative Code (WAC).

Committee Print Number 95-30 of the Committee on Public Works and Transportation of the House of Representatives, Table 1.

The Water Quality Guidance for the Great Lakes System, Table 6A. Volume 60 Federal Register, p. 15366. March 23, 1995.

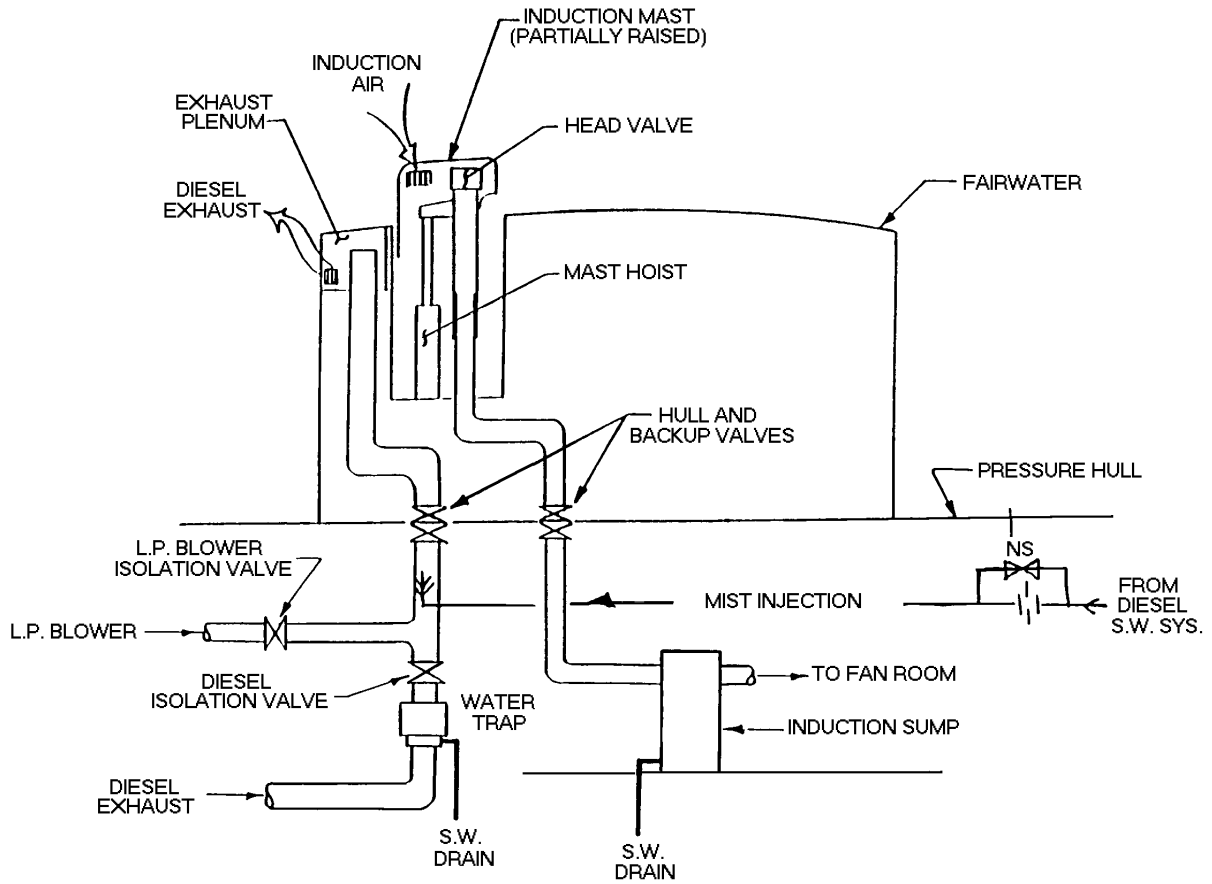

Figure 1. Typical Submarine Diesel Exhaust System

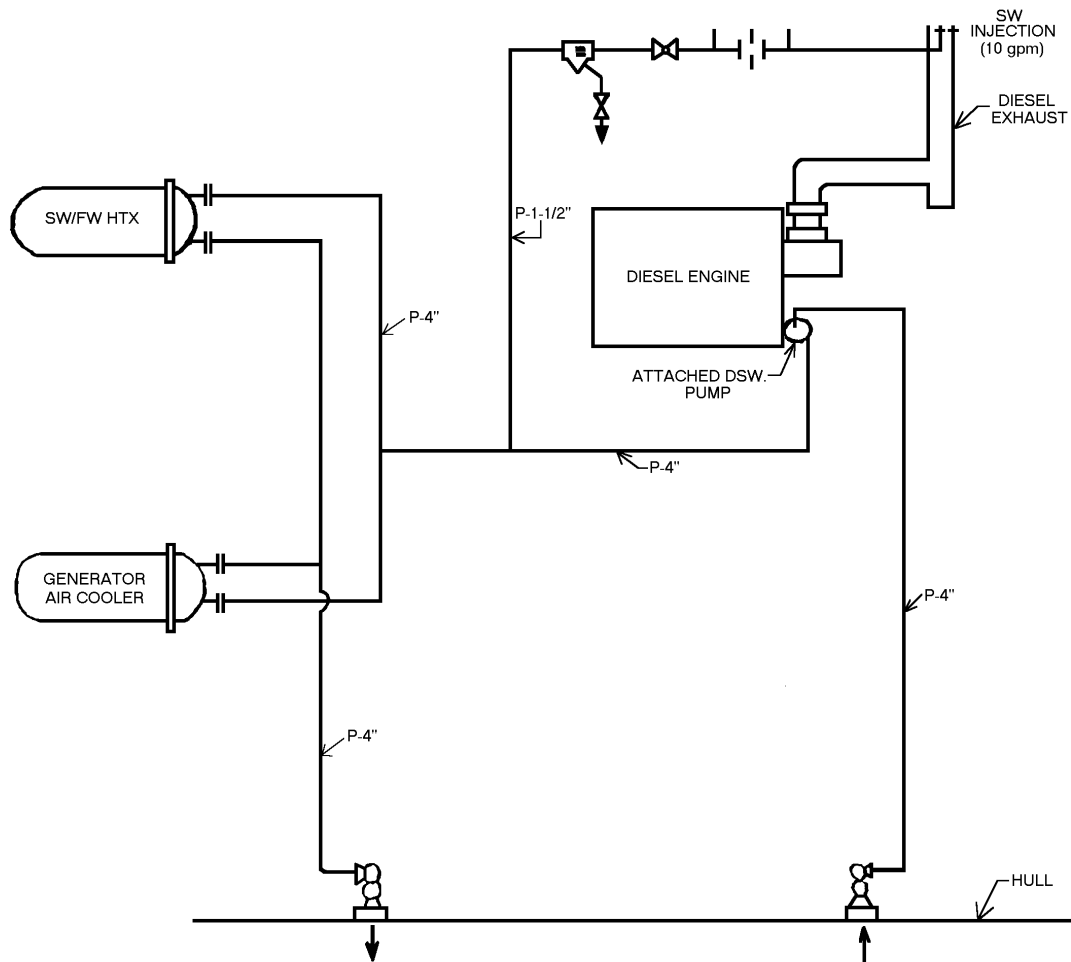

Figure 2. Typical Submarine Diesel Seawater System

**Table 1. Emergency Diesel Engine Applicable Vessels,
Air Exhaust and Cooling Water Flow Rates, and Estimated Annual Discharge**

Submarine Class	No. of Submarines	Air Exhaust Flow Rate (cubic feet per minute)	Cooling Water Injection Rate (gallons per minute)	Annual Discharge per Submarine (gallons)*	Annual Discharge for Class (million gallons)
SSN 688 (Los Angeles Class)	56	6500	11.5	41,400	2.3
SSBN 726 (Ohio Class)	17	8600	15.0	54,000	0.92
SSN 637 (Sturgeon Class)	13	3600	7.0	25,200	0.33
Total	86	N/A	N/A	N/A	3.55

* Based on 60-hour operating time annually per submarine

Table 2. Emission Factors for Large Uncontrolled Stationary Diesel Engines⁶

Constituent	Emission Factor	
	(lb/MMBtu) ^a	(ng/J) ^b
Benzene	7.76E-04	0.3337
Toluene	2.81E-04	0.1208
Xylenes	1.93E-04	0.0830
Formaldehyde	7.89E-05	0.0339
Acetaldehyde	2.52E-05	0.0108
Acrolein	7.88E-06	0.0034
NO _x	3.2	1376
CO	0.85	365.5
CO ₂	165	70950
Naphthalene	1.30E-04	0.0559
Acenaphthylene	9.23E-06	0.0040
Acenaphthene	4.68E-06	0.0020
Fluorene	1.28E-05	0.0055
Phenanthrene	4.08E-05	0.0175
Anthracene	1.23E-06	0.0005
Fluoranthene	4.03E-06	0.0017
Pyrene	3.71E-06	0.0016
Benzo(a)anthracene	6.22E-07	0.0003
Chrysene	1.53E-06	0.0007
Benzo(b)fluoranthene	1.11E-06	0.0005
Benzo(k)fluoranthene	2.18E-07	0.0001
Benzo(a)pyrene	2.57E-07	0.0001
Indeno(1,2,3-cd) pyrene	4.14E-07	0.0002
Dibenz(a,h) anthracene	3.46E-07	0.0001
Benzo(g,h,i) perylene	5.56E-07	0.0002

^a Gaseous emission factors expressed in pounds per million British thermal unit (lb/MMBtu)

^b To convert from lb/MMBtu to ng/J, multiply by 430

Table 3. Estimated Concentrations of Exhaust Constituents in Wet Diesel Exhaust (mg/L)

Submarine Class: Engine Power/Exhaust Rate:	SSN688, LA Class (800kW, 6500 cfm)	SSBN 726, Ohio Class (1000kW, 8600 cfm)	SSN 637, Sturgeon (460kW, 3600 cfm)
Exhaust Constituents			
Benzene	.000018	.000017	.000019
Toluene	.000005	.000005	.000006
Xylenes	.000004	.000004	.000004
Formaldehyde	.005749	.005431	.005969
Acetaldehyde	.00018	.00017	.000187
Acrolein	.000006	.000006	.000006
NOx	.013364	.008234	.009049
CO	.001814	.001714	.001884
CO ₂	9.028866	8.530179	9.373719
Naphthalene	.000038	.000036	.00004
Acenaphthylene	.0000004	.0000004	.0000005
Acenaphthene	.000002	.000002	.000003
Fluorene	.000019	.000018	.00002
Phenanthrene	.000129	.000122	.000134
Anthracene	.000003	.000002	.000003
Fluoranthene	.0000002	.0000002	.0000002
Pyrene	.000039	.000037	.000041
Benzo(a)anthracene	.000039	.000036	.00004
Chrysene	.000105	.000099	.000109
Benzo(b)fluoranthene	.000007	.000006	.000007
Benzo(k)fluoranthene	.0000004	.0000004	.0000004
Benzo(a)pyrene	.000012	.000011	.000012
Indeno(1,2,3-cd) pyrene	.000434	.00041	.00045
Dibenz(a,h) anthracene	.000339	.00032	.000352
Benzo(g,h,i) perylene	.000751	.00071	.00078

Note: Concentrations have been based on a water temperature of 60⁰F. **Bold** indicates that water quality criteria is exceeded (see Table 5).

Table 4. Fleet-Wide Estimated Annual Mass Loadings of Wet Diesel Exhaust Constituents Within 12 n.m. of Shore

Submarine Class:	SSN688 Class	SSBN 726 Class	SSN 637 Class	TOTAL FLEET WIDE	
	800 kW	1000 kW	460 kW		
Engine Power:	800 kW	1000 kW	460 kW		
Exhaust Rate:	6500 cfm	8600 cfm	3600 cfm		
No. Vessels:	56 Vessels	17 Vessels	13 Vessels		
Constituent	(kg)	(kg)	(kg)	(kg)	(lbs)
Polycyclic Aromatic Hydrocarbons (PAHs)					
Naphthalene	0.00033	0.00013	0.00005	0.00051	0.00112
Acenaphthylene	0.000004	0.000001	0.000001	0.000006	0.00001
Acenaphthene	0.00002	0.00001	0.000003	0.00003	0.00007
Fluorene	0.00017	0.00006	0.00002	0.00025	0.00056
Phenanthrene	0.00112	0.00042	0.00017	0.00171	0.00378
Anthracene	0.00002	0.00001	0.00000	0.00003	0.00008
Fluoranthene	0.000002	0.0000008	0.0000003	0.000003	0.00001
Pyrene	0.00034	0.00013	0.00005	0.00052	0.00115
Benzo(a)anthracene	0.00034	0.00013	0.00005	0.00051	0.00113
Chrysene	0.00091	0.00035	0.00014	0.0014	0.00308
Benzo(b)fluoranthene	0.00006	0.00002	0.00001	0.00009	0.0002
Benzo(k)fluoranthene	0.000003	0.000001	0.0000005	0.00001	0.00001
Benzo(a)pyrene	0.00010	0.00004	0.00002	0.00016	0.00035
Indeno(1,2,3-cd) pyrene	0.00377	0.00143	0.00057	0.00577	0.01272
Dibenz(a,h) anthracene	0.00295	0.00112	0.00044	0.00451	0.00995
Benzo(g,h,i) perylene	0.00654	0.00247	0.00098	0.01	0.02204

Note: **Bold** indicates that water quality criteria is exceeded (see Table 5).

Table 5. Comparison of Discharge Concentrations and Water Quality Criteria (µg/L)

Constituent	Estimated Discharge Concentration ¹	Federal Acute WQC	Most Stringent State Acute WQC
Polyaromatic Hydrocarbons (PAHs)			
Acenaphthylene	0.0005	None	0.031 (FL) ²
Phenanthrene	0.134	None	0.031 (FL) ²
Benzo(a)anthracene	0.04	None	0.031 (FL) ²
Chrysene	0.109	None	0.031 (FL) ²
Benzo(b)fluoranthene	0.007	None	0.031 (FL) ²
Benzo(k)fluoranthene	0.0004	None	0.031 (FL) ²
Benzo(a)pyrene	0.012	None	0.031 (FL) ²
Indeno(1,2,3-cd) pyrene	0.45	None	0.031 (FL) ²
Dibenzo (a,h) anthracene	0.352	None	0.031 (FL) ²
Benzo(g,h,i) perylene	0.78	None	0.031 (FL) ²
Total PAHs²	1.89		0.031 (FL)²

Notes:

Refer to federal criteria promulgated by EPA in its National Toxics Rule, 40 CFR 131.36 (57 FR 60848; Dec. 22, 1992 and 60 FR 22230; May 4, 1995)

Where historical data were not reported as dissolved or total, the metals concentrations were compared to the most stringent (dissolved or total) state water quality criteria.

Bold number indicates that water quality criteria is exceeded.

HI = Hawaii

FL = Florida

1: Highest concentration of three submarine classes

2: Florida criteria for total PAHs is for the total of the following individual PAH compounds: acenaphthylene, benzo-(a)anthracene, benzo(a)pyrene, benzo(b)fluoranthene, benzo(g,h,i)perylene, benzo(k)fluoranthene, chrysene, dibenzo(a,h)anthracene, indeno(1,2,3-cd)pyrene, and phenanthrene. Estimated discharge concentrations for total PAHs represent a sum of these chemicals.

Table 6. Data Sources

NOD Section	Data Source			
	Reported	Sampling	Estimated	Equipment Expert
2.1 Equipment Description and Operation				X
2.2 Releases to the Environment			X	X
2.3 Vessels Producing the Discharge	UNDS Database			X
3.1 Locality				X
3.2 Rate			X	X
3.3 Constituents			X	X
3.4 Concentrations			X	
4.1 Mass Loadings			X	
4.2 Environmental Concentrations			X	
4.3 Potential for Introducing Non-Indigenous Species			X	X

Calculation Sheet Benzene

Background:

Henry's Law was used to estimate the concentration of components in wet exhaust from submarine emergency diesel engines. This calculation sheet shows the calculation for the concentration of benzene in the wet exhaust of SSN 688 Class submarines. Calculations for the other exhaust components were similar.

An energy balance was used to determine the approximate wet exhaust equilibrium temperature. The resulting temperature was determined using an air exhaust flow rate of 6,500 cfm at 200 °F, and a water injection rate of 11.5 gpm at 60 °F. For this calculation, we assume the exhaust gas to have similar thermal properties to air.

ΔH : Change in enthalpy, m: mass of air or water, Cp: Specific heat capacity of air or water

$$\Delta H_{\text{exhaust gas}} = \Delta H_{\text{water}}$$

$$\Delta H_{\text{exhaust gas}} = mC_p (200^\circ\text{F} - T)$$

$$\begin{aligned} &= (6,500 \text{ ft}^3/\text{min.}) (0.0601 \text{ lb}_m/\text{ft}^3) (0.24 \text{ Btu}/\text{lb}_m^\circ\text{F}) (200^\circ\text{F} - T) \\ &= 93.76 \text{ Btu}/^\circ\text{F}\text{-min.} (200^\circ\text{F} - T) \quad (1) \end{aligned}$$

$$\Delta H_{\text{water}} = mC_p (T - 60^\circ\text{F}) = (11.5 \text{ gal}/\text{min.}) (8.345 \text{ lb}_m/\text{gal}) (1 \text{ Btu}/\text{lb}_m^\circ\text{F}) (T - 60^\circ\text{F})$$

$$= 95.97 \text{ Btu}/^\circ\text{F}\text{-min.} (T - 60^\circ\text{F}) \quad (2)$$

Setting (1) = (2) we obtain the following:

$$93.76 \text{ Btu}/^\circ\text{F}\text{-min.} (200^\circ\text{F} - T) = 95.97 \text{ Btu}/^\circ\text{F}\text{-min.} (T - 60^\circ\text{F})$$

$$93.76 (T) + 95.97 (T) = 200^\circ\text{F} (93.76) + 95.97 (60^\circ\text{F})$$

$$T = \mathbf{129.18^\circ\text{F}} = (9/5)^\circ\text{C} + 32 = \mathbf{54^\circ\text{C}}$$

This temperature was then used to determine the appropriate values for Henry's Law constants, which vary with temperature.

At dilute concentrations, the concentration of benzene dissolved in water can be found from Henry's Law:

$$X_{a, \text{exhaust}} = (H_a) (X_{a, \text{water}}) / (P_t)$$

Where:

$X_{a, \text{exhaust}}$: Mole Fraction of Benzene in Exhaust

H_a : Henry's Law Constant (atm)

$X_{a, \text{water}}$: Mole Fraction of Benzene in Water

P_t : Total Exhaust Pressure (atm)

Rearranging, Henry's Law can be rewritten as:

$$X_{a, \text{water}} = (X_{a, \text{exhaust}}) (P_t) / H_a$$

The mole fraction of benzene in exhaust can then be converted into a concentration of benzene in the wet exhaust in mg/L using the molecular weight of benzene.

Given Conditions and Assumptions:

55.56 moles H₂O in 1 liter [(mole H₂O / 18 g H₂O) (1000g / Liter H₂O) = 55.56 moles H₂O/L]
Exhaust temperature of 200°F (Reference 3)
6,500 cfm air exhaust flow rate for 800 kW diesel engine
0.334 ng/J generation rate of benzene
Backpressure on engine is approximately 70% above atmospheric when surfaced (P_t = 1.70 atm)
Molecular weight of benzene is 78.11 grams per mole (78,110 mg/mole)
Based on a water temperature of 54 °C (327.15 K), Henry's Law constants (in atm) for the constituents are the following:

Constituent	H_a (atm)
Benzene	7.30 E+03
Toluene	8.89E+03
Xylenes	8.56E+03
Formaldehyde	2.30E+00
Acetaldehyde	2.34E+01
Acrolein	2.22E+02
No _x	4.01E+04
CO	7.85E+04
CO ₂	3.06E+03
Naphthalene	5.71E+02
Acenaphthylene	3.45E+03
Acenaphthene	3.19E+02
Fluorene	1.13E+02
Phenanthrene	5.31E+01
Anthracene	7.96E+01
Fluoranthene	2.92E+03
Pyrene	1.59E+01
Benzo(a)anthracene	2.70E+00
Chrysene	2.44E+00
Benzo(b)fluoranthene	2.77E+01
Benzo(k)fluoranthene	9.17E+01
Benzo(a)pyrene	3.61E+00
Indeno(1,2,3-cd) pyrene	1.60E-01
Dibenz(a,h) anthracene	1.71E-01
Benzo(g,h,i) perylene	1.24E-01

The conversion of Henry's Law constants into common units is presented at the end of the calculation sheet.

Solution:

1) Total number of moles per cubic foot in the air exhaust, including constituents and circulated air, n_t

The number of moles per cubic foot can be determined using the ideal gas law; PV = n_tRT

Where:

- P: Pressure within the exhaust piping, 1.7 atm
- V: Volume of space occupied by gas (assume 1 ft³)
- R: Gas constant, 0.08206 L-atm/ K-mol
- T: Temperature, 327.15 K

Rearranging the ideal gas law equation and solving for n_t/V yields:

$$n_t/V = P/RT$$

$$n_t/V = (1.7\text{atm}) (28.32 \text{ L/ ft}^3) / ((0.08206 \text{ L-atm/ K-mol}) (327.15 \text{ K})) \\ = 1.79 \text{ moles/ ft}^3$$

2) Concentration of benzene in air exhaust, A_b

$$A_b = (0.334 \text{ ng/J}) (800 \text{ kW}) (3.6 \times 10^6 \text{ J/kW-Hr}) (10^{-9} \text{ g/ng}) (1000 \text{ mg/g}) (\text{min./}6500 \text{ ft}^3) (\text{Hr/}60 \text{ min.}) \\ A_b = 2.47 \times 10^{-3} \text{ mg/ft}^3 = (2.47 \times 10^{-3} \text{ mg/ft}^3) (\text{g/}1000 \text{ mg}) (\text{mole benzene / } 78.11 \text{ g}) \\ = 3.17 \times 10^{-8} \text{ moles benzene/ft}^3 \text{ exhaust}$$

3) Mole fraction of gas in exhaust, $X_{a, \text{exhaust}}$

$$X_{a, \text{exhaust}} = A_b / \text{total molar concentration} \\ X_{a, \text{exhaust}} = (3.17 \times 10^{-8} \text{ moles benzene/ ft}^3 \text{ exhaust}) / (1.79 \text{ total moles/ ft}^3 \text{ exhaust}) \\ X_{a, \text{exhaust}} = 1.77 \times 10^{-8} \text{ moles benzene/ mole exhaust}$$

4) Mole fraction of gas in water, $X_{a, \text{water}}$

$$X_{a, \text{water}} = (X_{a, \text{exhaust}}) (P_t) / H_a \\ X_{a, \text{water}} = (1.77 \times 10^{-8}) (1.70 \text{ atm}) / 7300 (\text{atm}) \\ X_{a, \text{water}} = 4.12 \times 10^{-12} \text{ moles benzene / mole water}$$

5) Concentration of gas in water:

Per 1 liter of water;

$$\text{Moles benzene} = (4.12 \times 10^{-12} \text{ moles benzene / mole H}_2\text{O}) (55.56 \text{ moles H}_2\text{O/ 1 liter}) = 2.29 \times 10^{-10} \text{ moles/L} \\ (2.29 \times 10^{-10} \text{ moles/L}) (78.11 \text{ g benzene/mole}) = 1.8 \times 10^{-8} \text{ g/L benzene} \\ (1.8 \times 10^{-8} \text{ g/L}) (1000 \text{ mg/g}) = \mathbf{1.8 \times 10^{-5} \text{ mg/L benzene}}$$

Determination of Henry's Constants

Henry's constants for the constituents of concern were available, but units and temperature for the constants varied between the references used. Henry's constants with the following units were available:

- 1) H_1 , atm
- 2) H_2 , atm-m³/mol

For purposes of clarity, the same calculation was used for each constituent of concern. It was therefore necessary to convert all of Henry's constants to atm units, (1).

- 1) Conversion from H_2 (atm-m³/mol) to H_1 (atm):

$$H_1 = (H_2 \text{ in atm-m}^3/\text{mol}) (55.6 \text{ mol water / L}) (L / 10^{-3} \text{ m}^3 \text{ water}) = H_2 * (55,600)$$

Henry's constants with the following temperatures in degrees Celsius were available:

- (1) 20 °C
- (2) 24 °C
- (3) 25 °C
- (4) 40 °C

Henry's constants increase on average about threefold for every 10 °C rise in temperature for most volatile hydrocarbons.^a Therefore, the constants will increase by a factor of $\Delta H = 3^{(\Delta T/10)}$. All of the constants were converted to 54 °C constants using the following conversions

For Henry's constant at 54 °C, and converting from Henry's constants at 20 °C, 24 °C, and 25 °C respectively:

$$H_{54} = (H_{20}) (41.9)$$

$$H_{54} = (H_{24}) (27)$$

$$H_{54} = (H_{25}) (24.2)$$

$$H_{54} = (H_{40}) (4.66)$$

Example - Henry's Constant Calculation

For Acrolein, Henry's constant was available in atm-m³/mol for 20 °C ($H_a = 9.54 \times 10^{-5}$)
Therefore, at 54°C, Henry's constant will be:

$$H_a (\text{atm}) = (9.54 \times 10^{-5} \text{ atm-m}^3/\text{mol}) (55,600 \text{ mol/m}^3) (41.9)$$
$$H_a = 222 \text{ atm}$$

Using this approach, the constants were converted to atm units as shown in the table on the following page.

Table of Henry's Constants

Temperature Source Units	54 °C Cooper^b (atm)	20 °C USEPA^c (atm-m³/mol)	25 °C Mackay^d (atm-m³/mol)	40 °C CH2M Hill^e (atm-m³/mol)	H_a for 54 °C (atm)
Benzene			5.43E-03		7.30 E+03
Toluene			6.61E-03		8.89E+03
Xylenes			6.37E-03		8.56E+03
Formaldehyde		9.87E-07			2.30E+00
Acetaldehyde				9.05E-05	2.34E+01
Acrolein		9.54E-05			2.22E+02
NO _x	4.01E+04				4.01E+04
CO	7.85E+04				7.85E+04
CO ₂	3.06E+03				3.06E+03
Naphthalene			4.24E-04		5.71E+02
Acenaphthylene		1.48E-03			3.45E+03
Acenaphthene			2.37E-04		3.19E+02
Fluorene			8.39E-05		1.13E+02
Phenanthrene			3.95E-05		5.31E+01
Anthracene			5.92E-05		7.96E+01
Fluoranthene			2.17E-03		2.92E+03
Pyrene			1.18E-05		1.59E+01
Benzo(a)anthracene		1.16E-06			2.70E+00
Chrysene		1.05E-06			2.44E+00
Benzo(b)fluoranthene		1.19E-05			2.77E+01
Benzo(k)fluoranthene		3.94E-05			9.17E+01
Benzo(a)pyrene		1.55E-06			3.61E+00
Indeno(1,2,3-cd) pyrene		6.86E-08			1.60E-01
Dibenz(a,h) anthracene		7.33E-08			1.71E-01
Benzo(g,h,i) perylene		5.34E-08			1.24E-01

Bold: Original Referenced Number

- a. Kavanaugh, Michael C. and R. Rhodes Trussell, Design of Aeration Towers to Strip Volatile Contaminants from Drinking Water. American Water Works Association, December, 1980.
- b. Cooper, David and F. Alley, Air Pollution Control, A Design Approach. Waveland Press, Inc., 1986.
- c. United States Environmental Protection Agency Office of Air Quality Planning and Standards. Ground-Water and Leachate Treatment Systems Manual. R-94, January 1995.
- d. Mackay, Donald and Wan Ying Shiu, A Critical Review of Henry's Law Constants for Chemicals of Environmental Interest. University of Toronto, Canada, 1981.
- e. CH2M Hill. Bay Area Sewage Toxic Emissions Model. Version 3, 1992.