

NATURE OF DISCHARGE REPORT

Rudder Bearing Lubrication

1.0 INTRODUCTION

The National Defense Authorization Act of 1996 amended Section 312 of the Federal Water Pollution Control Act (also known as the Clean Water Act (CWA)) to require that the Secretary of Defense and the Administrator of the Environmental Protection Agency (EPA) develop uniform national discharge standards (UNDS) for vessels of the Armed Forces for "...discharges, other than sewage, incidental to normal operation of a vessel of the Armed Forces, ..." [Section 312(n)(1)]. UNDS is being developed in three phases. The first phase (which this report supports), will determine which discharges will be required to be controlled by marine pollution control devices (MPCDs)—either equipment or management practices. The second phase will develop MPCD performance standards. The final phase will determine the design, construction, installation, and use of MPCDs.

A nature of discharge (NOD) report has been prepared for each of the discharges that has been identified as a candidate for regulation under UNDS. The NOD reports were developed based on information obtained from the technical community within the Navy and other branches of the Armed Forces with vessels potentially subject to UNDS, from information available in existing technical reports and documentation, and, when required, from data obtained from discharge samples that were collected under the UNDS program.

The purpose of the NOD report is to describe the discharge in detail, including the system that produces the discharge, the equipment involved, the constituents released to the environment, and the current practice, if any, to prevent or minimize environmental effects. Where existing process information is insufficient to characterize the discharge, the NOD report provides the results of additional sampling or other data gathered on the discharge. Based on the above information, the NOD report describes how the estimated constituent concentrations and mass loading to the environment were determined. Finally, the NOD report assesses the potential for environmental effect. The NOD report contains sections on: Discharge Description, Discharge Characteristics, Nature of Discharge Analysis, Conclusions, and Data Sources and References.

2.0 DISCHARGE DESCRIPTION

This section describes the rudder bearing lubrication discharge and includes information on the equipment used, its operation (Section 2.1), general description of the constituents of the discharge (Section 2.2), and the vessels that produce this discharge (Section 2.3).

2.1 Equipment Description and Operation

Rudder bearings support the rudder and allow it to turn freely. While there are small variations among similar rudder bearings systems, there are generally two major types of rudder bearings and two lubricating methods for each type, resulting in four different bearing/lubrication method combinations. They are:

- grease-lubricated roller bearings,
- oil-lubricated roller bearings,
- grease-lubricated stave bearings, and
- water-lubricated stave bearings.

Grease-lubricated Roller Bearings. The rudder stock arrangement for grease-lubricated roller bearings includes a void space between the lower bearing and the hull seal (Figure 1). This design prevents seawater from entering the bearing and causing damage. Water that leaks past the hull seal, as well as grease that leaks past the bearing seals, will enter the void space and drain to the bilge. Thus, discharges from grease-lubricated roller bearings contribute to the bilgewater discharge which is covered in a separate NOD report. Since 1970, grease-lubricated roller bearings have been preferred for use on rudder stocks.

Oil-lubricated Roller Bearings. There is no void space in the rudder stock arrangement used for oil-lubricated roller bearings and the bottom seal of the lower bearing serves as the hull seal (Figure 2). To prevent water from entering the bearing and causing damage, the oil is kept at a slight positive pressure relative to the surrounding seawater pressure by supplying the oil from an elevated “head” tank located above the waterline. If a leak occurs, this positive pressure will cause lubricating oil to leak directly into the sea.¹

Stave Bearings (Grease and Water Lubricated). This type of bearing is typically located outside of the hull (Figure 3). Stave bearings, which are similar in appearance to the wooden staves that make up a barrel, are typically made of a phenolic-resin material. Depending on the actual type, these stave bearings may be lubricated by grease or water. Grease, when used, is forced into the bearing to lubricate the area where the rudder stock and staves meet. Water-lubricated stave bearings are designed with passages which allow seawater to flow through the bearing. For classification purposes, the bushings found on small boats and craft are included in this subheading due to the similarities in function and design.

Hull seals are used with all types of rudder bearings. A hull seal is installed where the rudder stock penetrates the hull. This seal prevents seawater from entering the ship and damaging the lower bearing, while in the case of oil-lubricated roller bearings it also keeps the oil in the

bearing cavity from leaking to the sea. In many cases this seal is a type of lip seal but flax packing can be found on older ships. A lip seal consists of a rubber circular ring with a flexible lip. This lip has a narrow contact area that rubs on the circumference of the shaft, forming a seal. Flax packing seals in a similar fashion as several rows of the circular packing material rubs along the rudder stock. Minor leakage can occur in both cases and their rubbing contact will eventually cause wear on the rudder stock. Hull seals are inspected when the ship is in dry dock, typically every four or five years.

The potential of oil leakage from lip seals and flax packing is greatest when a vessel is underway and the rudder is in use rather than when pierside and the rudder is idle. When the vessel is underway, the action of turning exerts forces on the rudder and rudder stock that can cause a temporary gap in the seal or packing coverage. The harder the turn or higher the vessel speed, the greater these forces are and the greater the potential is for oil leakage and the amount of leakage.

The latest trend in rudder stock hull sealing is to use a face seal. These seals eliminate the minor leakage sometimes associated with lip seals and flax packing. Face seals move the sealing point away from the rudder stock to two circular, hard, mating faces. One half of the seal rotates with the rudder stock while the other half is rigidly attached to the hull of the ship. These mating faces are honed to very small tolerances and while rubbing together prevent liquids from seeping through their very fine and smooth contact area. Face seals used on rudder stocks are designed not to leak as a result of the forces placed on the rudder stock during turning.¹

2.2 Releases to the Environment

The two releases possible are oil from oil-lubricated roller bearings and grease from grease-lubricated stave bearings.

2.3 Vessels Producing the Discharge

All Navy surface ships have rudder bearings, except for those with steerable thrusters or cycloidal propellers, such as the MHC 51 Class minesweepers.¹ Vessels belonging to the Military Sealift Command (MSC), U.S. Coast Guard (USCG), Army, and Air Force also have rudder bearings.

Most rudder bearings (roller or stave) are grease-lubricated. Only the AS 36/39 Class and AOE 1 Class ships, which form 4 percent of the total number of Navy ships, have oil-lubricated rudder bearings. The T-AFS 1 and T-AE 26 Classes of MSC are also fitted with oil-lubricated rudder bearings. USCG vessels do not have oil-lubricated rudder bearings. The rudder bearings or bushings found on small boats and craft are typically made of self-lubricating materials and are either not lubricated or use water for lubrication.

Surface ship rudders with oil-lubricated roller bearings and grease-lubricated stave bearings have the potential to produce an oil or grease discharge. Table 1 lists the rudder bearing type and lubrication method for each Navy ship class. There are currently five Navy ships that use

oil lubrication for rudder bearings. Five AS 36/39 Class ships (submarine tenders) and four AOE 1 Class ships (fast combat support ships) were originally fitted with lip seals. Of the submarine tenders, AS 36 and AS 37 are being decommissioned.² The three remaining ships (AS 39-41) are currently scheduled to have their lip seals replaced with face seals. The replacements are expected to begin in 1999 and conclude in 2002.¹ Of the four AOE 1 Class ships, AOE 2 and AOE 3 have been fitted with face seals. The other two ships in the class are also scheduled to be fitted with the same type of face seal.³ Therefore, any discharges of oil from the rudder bearings on Navy vessels is expected to be eliminated in the next 4 to 5 years. Of the MSC ships, the T-AE 35 had the face seal installed in December 1997.⁴

USCG ships use water- and grease-lubricated bearings on their rudder stocks, as summarized in Table 2.⁵ Small boats and craft use bearings/bushings that are either self-lubricated or water-lubricated. The lubricity of the materials used in self-lubricated bearings/bushings is such that additional lubricants are not required; water-lubricated bearings/bushings are also made of special materials, but require water to be present on their contact surfaces for proper lubrication. Table 3 lists the rudder bearings/bushings found in USCG small boats and craft.⁶ The upper bearing/bushing of these small boats and craft is typically self- or grease-lubricated because it may not contact the water, while the lower bearing/bushing is lubricated by being submerged in the water. The USCG is increasing the use of self-lubricated bearing material in its ships and is reducing the use of grease as a lubricating material in all areas exposed to the sea and weather.⁵

Table 4 lists MSC vessels, including the type of bearing, method of lubrication, and allowable leakage rates. Eight TAE 26 Class and eight TAFS 1 Class vessels have oil lubricated bearings.

Army and Air Force vessels have rudder bearings similar to those found on Coast Guard vessels of comparable size.

3.0 DISCHARGE CHARACTERISTICS

This section contains qualitative and quantitative information which characterizes the discharge. Section 3.1 describes where the discharge occurs with respect to harbors and near-shore areas, Section 3.2 describes the rate of the discharge, Section 3.3 lists the constituents in the discharge, and Section 3.4 gives the concentrations of the constituents in the discharge.

3.1 Locality

This discharge can occur in port and while operating within 12 nautical miles (n.m.).

3.2 Rate

This discharge comprises the leaking of oil or the washout of grease from rudder bearings. For the oil discharge, rules-of-thumb for characterizing hull seal failure limit the hull seal leakage rates to one gallon per day at sea and one pint per day in port.² These rates are abnormally high

and are typically associated with a malfunctioning or failing seal. Little or no leakage would be expected from a properly functioning and maintained seal.

3.3 Constituents

In general, greases and lubricating oils are made from lubricating stocks generated during petroleum fractionation. These fractions contain organic compounds that are generally larger molecules, containing more than 17 carbon atoms. Lubricating oils are composed of aliphatic, olefinic, naphthenic (cycloparaffinic), and aromatic hydrocarbons, as well as additives, depending on their specific use. Lubricating oil additives may include antioxidants, bearing protectors, wear resisters, dispersants, detergents, viscosity index improvers, pourpoint depressors, and antifoaming and rust-resisting agents.⁷ Not all the additives may be present at one time. It is anticipated that the additives are similar to those found in commercial oils. There are no bioaccumulators expected to be present in this discharge.

3.4 Concentrations

The greases and lubricating oils used conform to MIL-G-24139 specifications and 2190TEP (MIL-L-17331) respectively.¹ Based on MSDS information, MIL-G-24139 grease contains 86% hydrotreated heavy paraffinic distillates, 6% clay, and 4% fatty acid amides. Lubricating oil 2190 TEP contains greater than 99% heavy hydrotreated paraffinic distillates and less than 1% additives.

4.0 NATURE OF DISCHARGE ANALYSIS

Based on the discharge characteristics presented in Section 3.0, the nature of the discharge and its potential impact on the environment can be evaluated. The estimated mass loadings are presented in Section 4.1. In Section 4.2, the concentrations of discharge constituents after release to the environment are estimated and compared with the water quality standards. In Section 4.3, the potential for the transfer of non-indigenous species is discussed.

4.1 Mass Loading

4.1.1 Oil

At Sea. A high estimate of the oil released by a ship at sea is one gallon of oil per day, as discussed in Section 3.2. It is also estimated that it takes 4 hours for a ship to cover the 12 n.m. transit zone. Therefore, during each transit (either into or out of port), one-sixth of a gallon of oil could be released. An AOE 1 Class ship averages 22 transits per year and an AS 36/39 Class ship averages 12 transits per year. Under this scenario, an AOE 1 Class ship could release $(1/6)(22) = 3.7$ gallons of oil and an AS 36/39 Class ship would release $(1/6)(12) = 2.0$ gallons of oil to the surrounding seawater each year. As stated in Section 2.3, two AOE 1 Class ships and 3 AS 36/39 Class ships have oil-lubricated bearings. The maximum estimated amount of oil released from Navy ships fleetwide per year within 12 n.m. would be $(3.7)(2) + (2.0)(3) = 13.4$ gallons. Using a

specific gravity of 0.89 for oil (MSDS for 2190TEP), this translates into approximately 100 pounds per year (lbs/year).

Using the same logic for the MSC ships, eight T-AE 26 Class (8 transits) and eight T-AFS 1 Class (14 transits), the total mass loading would be:

$$(1/6 \text{ gallons})(8 \text{ transits})(8 \text{ ships}) + (1/8 \text{ gallons})(14 \text{ transits})(8 \text{ ships}) = 29.3 \text{ gallons or } 218 \text{ lbs/year}$$

Therefore, the total mass loading at sea during transit would be $100 + 218 = 318$ lbs/year. However, the actual release rates will be much less because all ships of a class will not leak oil at such high rates, for such a long period of time, at the same time.

In Port. A high estimate of the oil released by a ship in port is one pint per day, as discussed in Section 3.2. Assuming that each of the two AOE 1 Class and three AS 36/39 Class ships spend 183 days per year in port, the total amount of oil released would be $(1 \text{ pint})(5 \text{ ships})(183 \text{ days/yr}) = 915$ pints or 114 gallons per year. This translates into approximately 846 lbs/year.

For the eight MSC ships, the total amount of oil released in port would be:

$$(1 \text{ pint})(8 \text{ ships})(183 \text{ days/year}) = 1,460 \text{ pints/year, } 183 \text{ gallons/year, or } 1,360 \text{ lbs/year.}$$

Therefore, the maximum estimated mass loading in port would be $846 + 1,360 = 2,206$ lbs/year. However, the actual release rates are expected to be much less because all ships of a class will not leak oil at such high rates, for such a long period of time, at the same time.

4.1.2 Grease

Grease washout occurs only from grease-lubricated stave bearings and only when the ship is moving and the rudder is in use. When the ship is first constructed or when the bearings are overhauled, approximately 2 pounds of grease are used for the entire bearing.¹ During the required, biweekly lubrication of these bearings, the grease is topped-off to replenish the amount lost while cruising at sea and, therefore, less than 2 pounds are used. Specifications for MIL-G-24139 grease require that no more than 5 percent of the grease may wash out when tested in accordance with the ASTM D-1264 method. It was estimated that for every two weeks underway (in accordance with the biweekly maintenance requirement), 5 percent of the grease is washed out and is subsequently replenished. Therefore, a maximum of 0.1 pounds of grease (5% of 2 lbs.) are estimated to be washed out every two weeks underway.

Since the release of grease only occurs through erosion while the ship is moving through the water, discharges of grease are not expected in port. The 0.1-pound biweekly washout estimate can be used to calculate the grease washed out per transit. Based on vessel monitoring data, each vessel, on average, makes 24 transits a year within the 12 n.m. zone.⁸ Each round trip transit (including inbound and outbound transits) lasts approximately 8 hours (0.024 weeks).

Therefore, on each transit, 0.0024 pounds of grease could be discharged (i.e. 0.1 pounds per week multiplied by 0.024 weeks). Fleetwide, for the 56 vessels that have stave bearings, the mass loading would be 3.23 pounds (0.0024 pounds per transit x 24 transits per vessel x 56 vessels) within the 12 n.m. zone.

4.2 Environmental Concentrations

4.2.1 Lubricating Oil

At Sea. An estimate was made of the amount of water swept by an AOE 1 Class ship while in transit. Any rudder bearing oil leaking while underway will be churned into this volume by the propellers. An AOE 1 Class ship is 107 feet wide. For a draft (depth of ship bottom) of 39 feet and a length of 12 n.m. (72,960 feet), the total volume of water swept is $(107)(39)(72,960) = 304$ million cubic feet or 8 billion liters. Therefore, on each transit through the 12 n.m. zone, for each AOE 1 Class ship, one-sixth of a gallon of oil (i.e., 630 mL) is released in 8 billion liters of seawater. Using a specific gravity of 0.89 for oil (MSDS for 2190TEP), this translates into a maximum estimated concentration of 7×10^{-5} milligrams per liter (mg/L).

A similar estimate can be made for an AS 36/39 Class ship that is 85 feet wide. For a draft of 25.5 feet and a length of 12 n.m. (72,960 feet), the total volume of water swept is $(85)(25.5)(72,960) = 158$ million cubic feet or 4.5 billion liters. Therefore, on each transit through the 12 n.m. zone, for each AS 36/39 Class ship, one-sixth of a gallon of oil (i.e., 630 mL) is released in 4.5 billion liters of seawater. This translates into a maximum estimated concentration of 1.2×10^{-4} mg/L.

MSC ships with oil-lubricated rudder bearings (T-AE 26 and T-AFS 1 Classes) have an average width of 80 feet and an average draft of 26 feet. Therefore, as calculated above for the Navy ships, the oil concentration resulting from these ships would be approximately 1.3×10^{-4} mg/L.

In Port. While in port the ship is stationary. Any oil that leaks from the rudder bearings will be mixed continuously with the water surrounding the rudder stock at the stern of the ship. The leakage of oil will be continuous over the day, so if the maximum allowable release of one pint daily (.125 gallons) were divided by 1440 minutes per day, the discharge rate would be 8.68×10^{-5} gallons per minute. It is assumed that local currents will displace 5 cubic feet of water (37.4 gallons) from the area around the rudder stock at least once per minute. Calculating the concentration of oil within the volume displaced during one minute yields a local concentration of about 2.1 mg/L.

4.2.2 Grease

Because grease-lubricated stave bearings are installed in several vessel classes, a vessel width of 80 feet and a draft of 25 feet were assumed in the calculations. Following calculations similar to the ones in Section 4.2.1, the total volume of water swept would be 255 million cubic feet or 7 billion liters. As calculated in Section 4.1, a maximum of 0.0024 pounds (or 1.1 grams)

of grease is released during each trip. This translates into a concentration of 1.6×10^{-10} mg/L.

Based on the environmental concentrations estimated in Sections 4.2.1 and 4.2.2 above, a high estimate of the oil and grease concentration in the surrounding water would be 1.3×10^{-4} mg/L at sea, and 2.1 mg/L in port. These concentrations do not exceed federal discharge standards or the most stringent state water quality criteria, as shown in Table 5.

4.3 Potential for Introducing Non-Indigenous Species

There is no potential for the transport of non-indigenous species since seawater is not taken aboard or discharged.

5.0 CONCLUSIONS

The rudder bearing lubrication discharge has a low potential for causing an adverse environmental effect because the concentrations of oil and grease in the environment from rudder bearing lubrication while the ship is within the 12 n.m. zone are below relevant federal discharge standards and state water quality criteria.

6.0 DATA SOURCES AND REFERENCES

To characterize this discharge, information from various sources were obtained. Process information and assumptions were used to estimate the rate of discharge. Based on this estimate and on the reported concentrations of oil and grease components, the concentrations of oil and grease in the environment resulting from this discharge were then estimated. Table 6 lists the data sources used to develop this NOD report.

Specific References

1. UNDS Equipment Expert Meeting Minutes. Rudder Bearing Lubrication Leakage. September 26, 1996.
2. UNDS Round 2 Equipment Expert Meeting Minutes. Rudder Bearing Lubrication Leakage. March 6, 1997.
3. Personal communication between Penny Weersing (MSC) and David Eaton (MR&S) concerning Action Item RT1. April 16, 1997.
4. Personal communication between Rich Machinsky (MSC) and Dick Soule (MR&S). April 9, 1998.
5. Personal communication between LT Joyce Aivalotis (USCG) and David Eaton (MR&S). May 2, 1997.

6. Report of April 1997 Trip to USCG, Baltimore to Research Rudder Bearings on USCG Small Boats and Craft. January 13, 1998.
7. Patty's Industrial Hygiene & Toxicology, 3rd Ed., Volume 2B. 1981. John Wiley & Sons, New York, pp 3369, 3397.
8. Pentagon Ship Movement Data for Years 1991-1995. March 4, 1997.

General References

- USEPA. Toxics Criteria for Those States Not Complying with Clean Water Act Section 303(c)(2)(B). 40 CFR Part 131.36.
- USEPA. Interim Final Rule. Water Quality Standards; Establishment of Numeric Criteria for Priority Toxic Pollutants; States' Compliance – Revision of Metals Criteria. 60 FR 22230. May 4, 1995.
- USEPA. Water Quality Standards; Establishment of Numeric Criteria for Priority Toxic Pollutants. 57 FR 60848. December 22, 1992.
- USEPA. Water Quality Standards; Establishment of Numeric Criteria for Priority Toxic Pollutants for the State of California, Proposed Rule under 40 CFR Part 131, Federal Register, Vol. 62, Number 150. August 5, 1997.
- Connecticut. Department of Environmental Protection. Water Quality Standards. Surface Water Quality Standards Effective April 8, 1997.
- Florida. Department of Environmental Protection. Surface Water Quality Standards, Chapter 62-302. Effective December 26, 1996.
- Georgia Final Regulations. Chapter 391-3-6, Water Quality Control, as provided by The Bureau of National Affairs, Inc., 1996.
- Hawaii. Hawaiian Water Quality Standards. Section 11, Chapter 54 of the State Code.
- Mississippi. Water Quality Criteria for Intrastate, Interstate and Coastal Waters. Mississippi Department of Environmental Quality, Office of Pollution Control. Adopted November 16, 1995.
- New Jersey Final Regulations. Surface Water Quality Standards, Section 7:9B-1, as provided by The Bureau of National Affairs, Inc., 1996.
- Texas. Texas Surface Water Quality Standards, Sections 307.2 - 307.10. Texas Natural Resource Conservation Commission. Effective July 13, 1995.

Virginia. Water Quality Standards. Chapter 260, Virginia Administrative Code (VAC) , 9 VAC 25-260.

Washington. Water Quality Standards for Surface Waters of the State of Washington. Chapter 173-201A, Washington Administrative Code (WAC).

Committee Print Number 95-30 of the Committee on Public Works and Transportation of the House of Representatives, Table 1.

The Water Quality Guidance for the Great Lakes System, Table 6A. Volume 60 Federal Register, p. 15366. March 23, 1995.

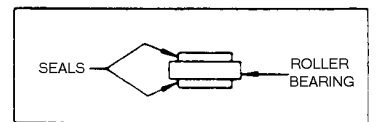
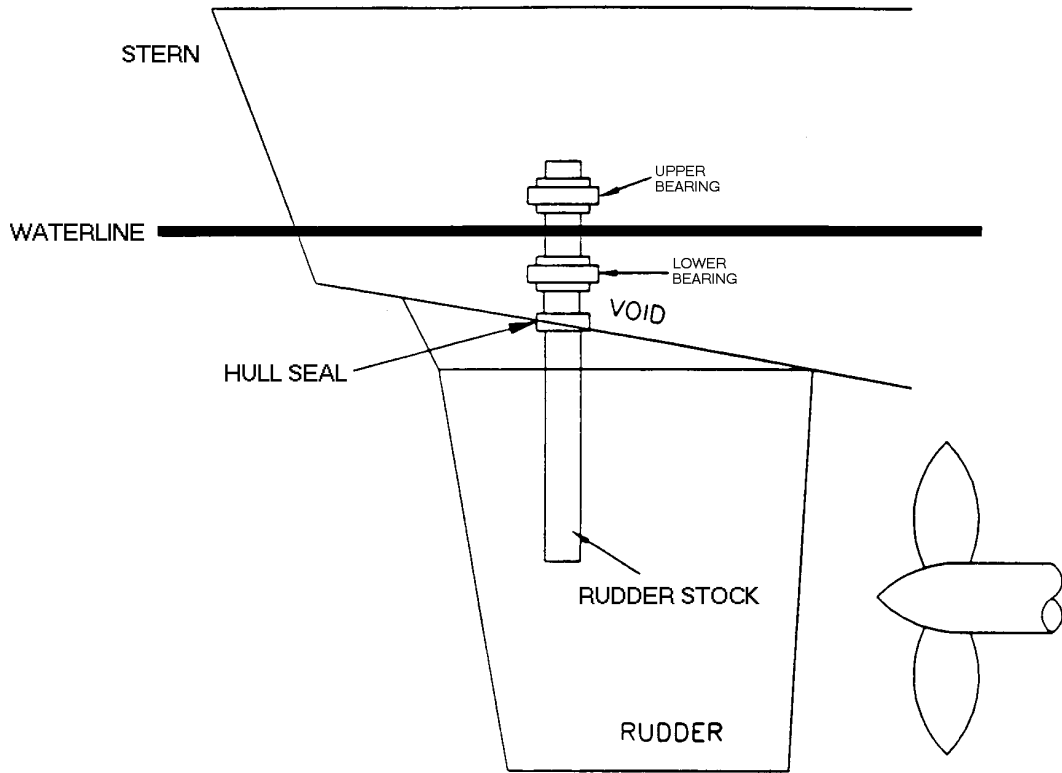

Figure 1. Rudder Grease-Lubricated Roller Bearings Generic Sketch

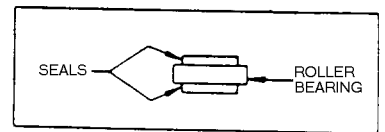
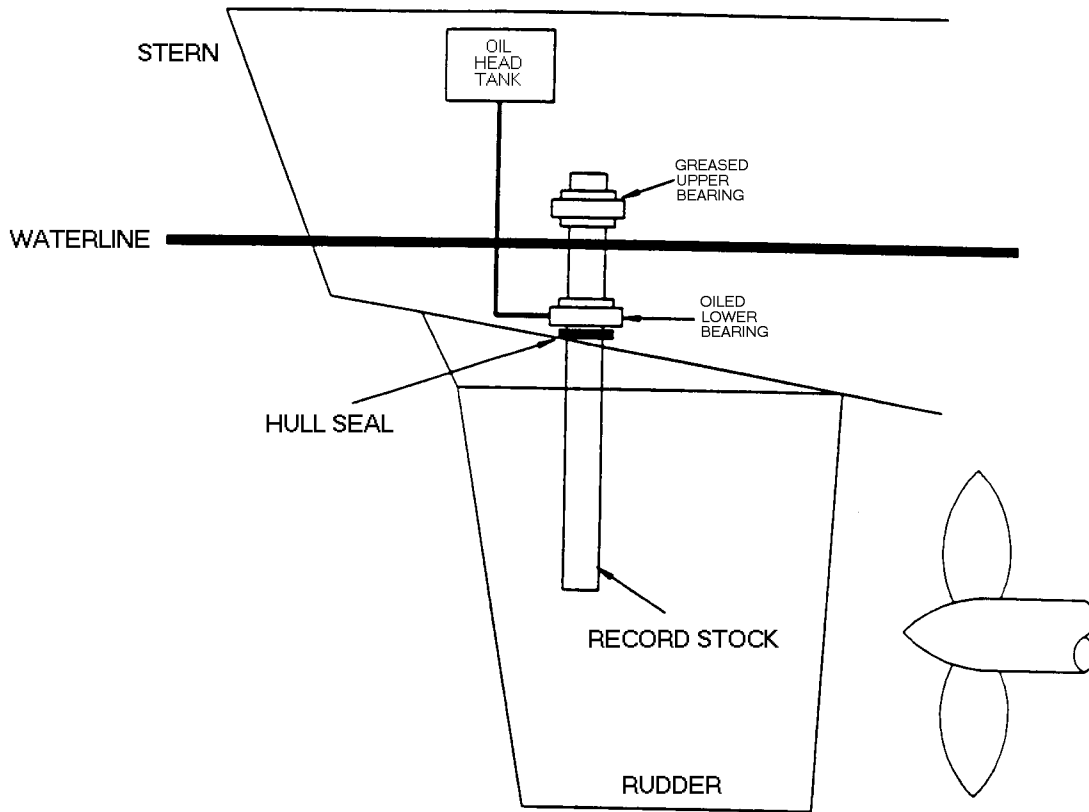

Figure 2. Rudder Oil-Lubricated Roller Bearings Generic Sketch

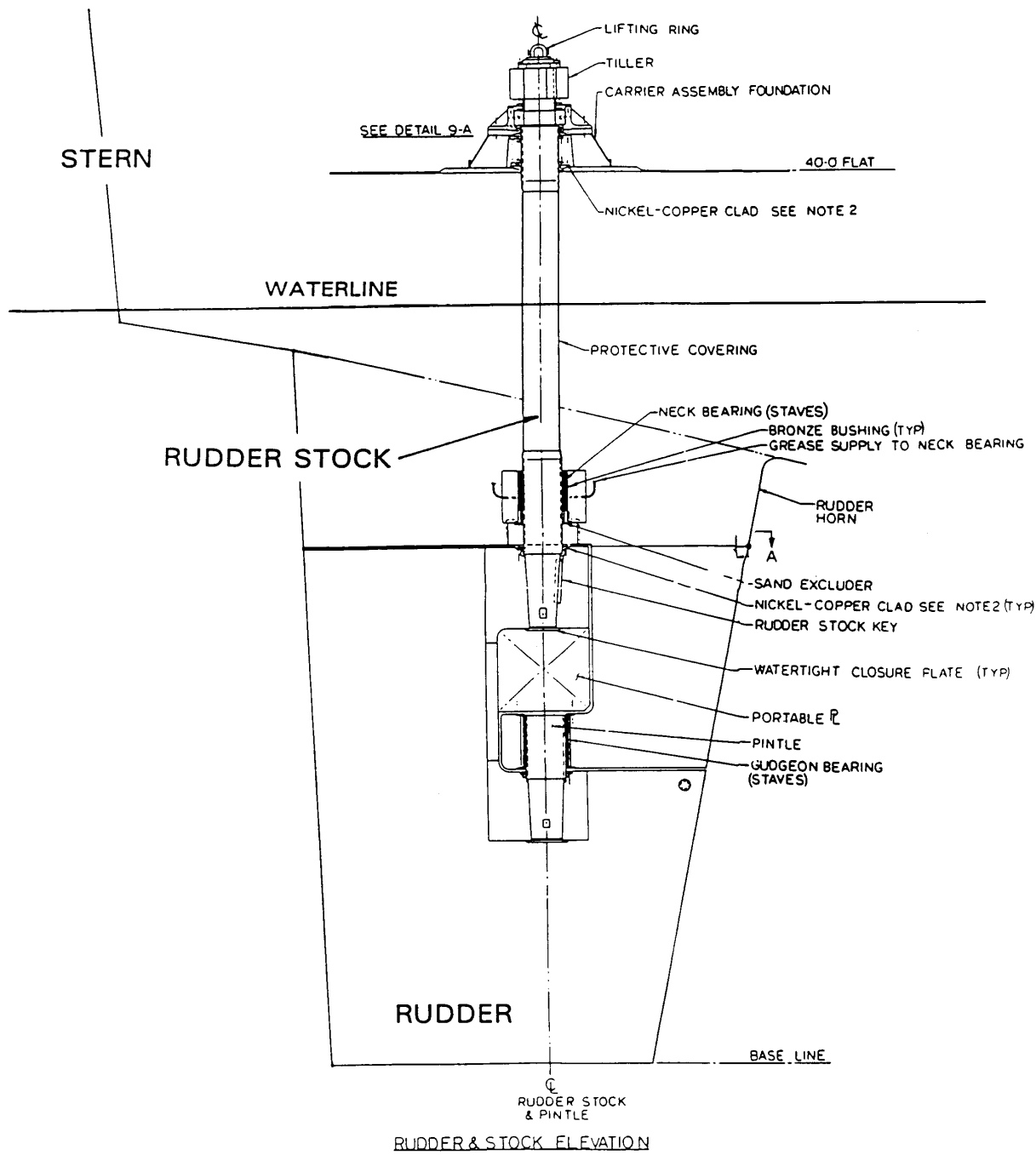

Figure 3. Rudder Stave Bearings (Example)

Table 1. Navy Ships - Lower Rudder Bearing Type and Lubrication Method

Ship Class	Lower Rudder Bearing & Type of Lubrication	# in Class
AGF 3	Stave Brg., Grease	1
AGF 11	Stave Brg., Grease	1
AO 177	Roller Brg., Grease	13
AOE 1	Roller Brg., Oil/Grease	2/2
AOE 6	Stave Brg., Grease	3
ARS 50	Stave Brg., Grease	4
AS 36/39	Roller Brg., Oil	3
ATS 1	Stave Brg., Grease	3
CG 47	Roller Brg., Grease	27
CGN 36	Stave Brg., Water	2
CGN 40	Stave Brg., Water	1
CV 62	Stave Brg., Water	1
CV 63	Stave Brg., Water	2
CV 67	Stave Brg., Water	1
CVN 65	Stave Brg., Water	1
CVN 68	Stave Brg., Water	7
DD 963	Roller Brg., Grease	31
DDG 51	Roller Brg., Grease	18
DD 993	Roller Brg., Grease	4
FFG 7	Roller Brg., Grease	43
LCC 19	Stave Brg., Grease	2
LHA 1	Roller Brg., Grease	5
LHD 1	Roller Brg., Grease	4
LPD 4	Stave Brg., Grease	9
LPH 2	Stave Brg., Grease	2
LSD 36	Stave Brg., Grease	5
LSD 41	Stave Brg., Grease	11
MCM 1	Stave Brg., Grease	14
MCS 12	Stave Brg., Grease	1
		223

Table 2. U.S. Coast Guard Cutters, Types of Bearing, and Lubrication

Cutter Class	No. in Class	Type of Bearing	Lubrication
399 WAGB	2	Laminated Phenolic Staves	Grease
378 WHEC	12	Micarta Bushing	Flax Packing/Grease
270 WMEC	13	Bushings	Grease/Water
210 WMEC	16	Micarta Bushing	Grease
140 WTGB	9	Staves	Water

Note: There is no information available on the following classes:

225 WLB	New production
175 WLM	New production
180 WLB	Decommissioned by 2001
157 WLM	Decommissioned by 2000
133 WLM	Decommissioned by 2000
160 WLIC	No information

**Table 3. U.S. Coast Guard Small Boats and Craft
(Types of Bearings and Lubrication)**

Vessel/Craft	Type	Upper Rudder Bearing	Method of Lubrication	Lower Rudder Bearing	Method of Lubrication
26' MSB	motor surfboat	Thordon SXL bushing	self	Thordon SXL bushing	water
32' PWB	ports & waterways boat	Delrin or nylon bushing	self	Delrin or nylon bushing	water
44' MLB(S)	motor lifeboat (steel)	Micarta bushing	self	Micarta bushing	water
47' MLB	motor lifeboat	Thordon SXL	self	Thordon SXL bushing	water
52' MLB(S)	motor lifeboat (steel)	ball bearing	grease	Micarta bushing	water
55' ANB	aid to navigation boat	metal bushing	grease	metal bushing	grease
65' WLR	river buoy tender	spherical roller bearing	grease	Goodrich cutless bearing	water
65' WYTL	tug boat (steel)	roller bearing	grease	Micarta bushing	water
75' WLIC	inland construction tender	spherical roller bearing	grease	bronze bushing	grease
75' WLR	river buoy tender	spherical roller bearing	grease	Thordon XL bushing	water
82' WPB	patrol boat	spherical roller bearing	grease	Micarta bushing	water
110' WPB	patrol boat	spherical roller bearing	grease	bushing	water

**Table 4. Military Sealift Command Ships
(Type of Rudder Bearings and Lubrication)**

SHIP CLASS/NAME	APL	BEARING TYPE/LUBRICATION		ALLOWABLE SEAL LEAKAGE WATER OR OIL	REMARKS
		UPPER & LOWER RUDDER STOCK	PINTLE BEARING		
T-AE 26/ USNS KILAUEA	319010122	ROLLER BEARING/ OIL	STAVE/ WATER	1 PINT/DAY IN PORT/ANCHOR. 1 GALLON/DAY UNDERWAY	RUDDER POST HAS NEW JOHN CRANE SPLIT SEAL INSTALLED DURING YARD PERIOD
T-AFS 1/ USNS MARS	319010106	ROLLER BEARING/OIL			
T-AG 194/ USNS VANGUARD					NO DATA AVAILABLE
T-AGM 22/ USNS RANGE SENTINEL					NO DATA AVAILABLE
T-AGOS 21/ USNS EFFECTIVE		AEROSHELL GREASE 6SG6127 70026		1 PINT/DAY IN PORT/ANCHOR. 1 QUART/DAY FOR ALL OPERATING CONDITIONS	
T-AGS 45/ USNS WATERS	M319010192	ROLLER/GREASE	STAVE/ WATER	1 PINT/DAY IN PORT /ANCHOR. 1 GAL./DAY FOR ALL OPERATING CONDITIONS.	
T-AGS 60/ USNS PATHFINDER	N.A	N.A	N.A	N.A.	THIS CLASS HAS "ZEE" DRIVES . THERE ARE NO RUDDERS.
T-AH 19/ USNS MERCY					NO DATA AVAILABLE
T-AO 187/ USNS HENRY J. KAISER		ROLLER/GREASE		1 PINT/DAY IN PORT/ANCHOR. 1 QUART/DAY FOR ALL OPERATING CONDITIONS	
T-ARC 7/ USNS ZEUS					NO DATA AVAILABLE
T-ATF 166/ USNS POWHATAN					NO DATA AVAILABLE

The blank spaces in the table indicate that information is not available.

Table 5. Comparison of Environmental Concentration with Relevant Water Quality Criteria (mg/L)

Constituent	Concentration	Federal Discharge Standard	Most Stringent State Water Quality Criteria
oil and grease	1.3 x 10 ⁻⁴ (at sea) 2.1 (in port)	visible sheen ^a /15 ^b	5.0 (FL)

Notes:

Refer to federal criteria promulgated by EPA in its National Toxics Rule, 40 CFR 131.36 (57 FR 60848; Dec. 22, 1992 and 60 FR 22230; May 4, 1995)

^a *Discharge of Oil*, 40 CFR 110, defines a prohibited discharge of oil as any discharge sufficient to cause a sheen on receiving waters.

^b *International Convention for the Prevention of Pollution from Ships* (MARPOL 73/78) as implemented by the *Act to Prevent Pollution from Ships* (APPS)

Table 6. Data Sources

NOD Section	Data Source			
	Reported	Sampling	Estimated	Equipment Expert
2.1 Equipment Description and Operation				X
2.2 Releases to the Environment				X
2.3 Vessels Producing the Discharge	UNDS Database			X
3.1 Locality				X
3.2 Rate			X	
3.3 Constituents	X			X
3.4 Concentrations	X			X
4.1 Mass Loadings			X	
4.2 Environmental Concentrations			X	
4.3 Potential for Introducing Non-Indigenous Species			X	X