

# NATURE OF DISCHARGE REPORT

## *Submarine Outboard Equipment Grease and External Hydraulics*

### 1.0 INTRODUCTION

The National Defense Authorization Act of 1996 amended Section 312 of the Federal Water Pollution Control Act (also known as the Clean Water Act (CWA)) to require that the Secretary of Defense and the Administrator of the Environmental Protection Agency (EPA) develop uniform national discharge standards (UNDS) for vessels of the Armed Forces for "...discharges, other than sewage, incidental to normal operation of a vessel of the Armed Forces, ..." [Section 312(n)(1)]. UNDS are being developed in three phases. The first phase (which this report supports) will determine which discharges will be required to be controlled by marine pollution control devices (MPCDs) -- either equipment or management practice. The second phase will develop MPCD performance standards. The final phase will determine the design, construction, installation, and use of MPCDs.

A nature of discharge (NOD) report has been prepared for each of the discharges that has been identified as a candidate for regulation under UNDS. The NOD reports were developed based on information obtained from the technical community within the Navy and other branches of the Armed Forces with vessels potentially subject to UNDS, from information available in existing technical reports and documentation, and, when required, from data obtained from discharge samples that were collected under the UNDS program.

The purpose of the NOD report is to describe the discharge in detail, including the system that produces the discharge, the equipment involved, the constituents released to the environment, and the current practice, if any, to prevent or minimize environmental effects. Where existing process information is insufficient to characterize the discharge, the NOD report provides the results of additional sampling or other data gathered on the discharge. Based on the above information, the NOD report describes how the estimated constituent concentrations and mass loading to the environment were determined. Finally, the NOD report assesses the potential for environmental effect. The NOD report contains sections on: Discharge Description, Discharge Characteristics, Nature of Discharge Analysis, Conclusions, and Data Sources and References.

## 2.0 DISCHARGE DESCRIPTION

This section describes the submarine outboard equipment grease and external hydraulics discharge and includes information on: the equipment that is used and its operation (Section 2.1), general description of the constituents of the discharge (Section 2.2), and the vessels that produce this discharge (Section 2.3).

### 2.1 Equipment Description and Operation

This discharge occurs when grease applied to a submarine's outboard equipment is released to the environment by erosion from the mechanical action of the seawater while the submarine is underway and, to a much lesser extent, by slow dissolution of the grease into seawater. The discharge also includes any hydraulic oil that could leak past the seals of the hydraulically operated external components of a submarine.

#### 2.1.1 Grease from Outboard Equipment

Submarine outboard equipment that requires lubrication includes steering and diving control mechanisms and control surface bearings. Grease is applied quarterly while a submarine is in port.<sup>1</sup> Figure 1 shows the various grease points on a submarine that can come into contact with seawater under partially or completely submerged conditions. Of these, the ones that are operated within 12 nautical miles (n.m.) and could release grease to the environment are the retractable bow planes, and the fairwater (sail planes). The retractable bow plane components require the largest amount of grease for operation. Figure 2 is a cut-away diagram of the retractable bow plane cavity where grease is applied to its various components.

**Bow Plane Mechanisms.** The retractable bow planes are a set of fins or control surfaces that are housed within the envelope of the hull and are extended to provide depth control while the submarine is moving underwater. These bow planes have mechanisms that slide in and out causing the bow planes to change position in response to commands from the helm. The sliding components are lubricated by an automatic system that applies grease every time they move back and forth. This movement may cause some grease to loosen and detach from the components and deposit in the bow plane compartment (20 feet wide by 6 feet long by 5 feet high) which is in contact with the sea through a narrow, half-inch-wide gap around each bow plane. Because of this relatively narrow opening to the sea as well as a protective brush that covers this gap completely around the retractable bow plane, the probability of loose grease in the cavity washing out of the compartment is low. Currently, only 22 submarines have retractable bow plane compartments, but future design trends will increase this number.<sup>2</sup>

**Fairwater Plane Mechanisms.** Submarines that do not have retractable bow planes have control surfaces that perform a similar function, but which are located on the sail structure. These are the fairwater planes. Currently, there about 72 submarines in the fleet with fairwater planes. Fairwater planes have components similar to the retractable bow planes that also lubricated by greasing, but the components do not contact seawater while the submarine is within 12 n.m. because the fairwater planes are located well above the water line when the submarine is surfaced.

### **2.1.2 External Hydraulics**

The external hydraulic system on a submarine supplies hydraulic fluid under pressure to operate the following equipment:

- masts (e.g. radio antennas, radar, electronic counter measures, etc.), periscopes, and their associated fairings (e.g., hydrodynamic covers for the various masts and periscopes needed to reduce the turbulence while the submarine is running submerged with the masts and/or periscopes raised);
- retractable bow plane actuator mechanisms; and
- secondary propulsion motor hoist cylinders located outside the pressure hull.

Figure 3 shows the location of masts, antennas, and periscopes on a submarine's hull. The secondary propulsion motor hoist cylinders (not shown in the figure) are located in an aft ballast tank.

Navy submarines use specially formulated oil in their external hydraulic systems. The hydraulic oil is normally pressurized to approximately 1,400 pounds per square inch (psi) and stored in a reservoir that holds approximately 200 gallons. The total amount of hydraulic oil in the system, including that in piping and the reservoir, is approximately 250 gallons. On submarines that have hydraulically-operated retractable bow planes (22 of 94 submarines), the total amount of hydraulic oil is approximately 400 gallons.<sup>3</sup> Of those items identified above operated by the external hydraulic system, only the retractable bow plane actuator mechanisms will have any possible release to the environment. In the case of the masts, antennas, and periscopes, they are located well above the waterline, well away from any contact with the seawater, where there is no possible erosion of the any oil film generated by the equipments' operation. In the case of the secondary propulsion motor, it is only operated in rare emergency situations, and as such is not covered by the UNDS criteria.

## **2.2 Releases to the Environment**

Grease transport is produced through the mechanical action of the water against components covered with grease. Underway, some of the loose grease in the bow plane compartment can be eroded by the mechanical action of the flowing seawater. The amount of grease released is directly proportional to the force of turbulent water in the vicinity of the grease resulting in erosion, which, in turn, is directly proportional to submarine speed. Within 12 n.m., a submarine's speed is low by comparison to its speed when submerged. It increases speed once it submerges. Therefore, the amount of mechanical erosion within the 12 n.m. zone is less than when the submarine is in open ocean.

Very little, if any, grease is discharged when a submarine is pierside because the outboard equipment is not being actuated, and the erosive action of seawater is minimal when the submarine is stationary.

Periodically, when the submarine is dry docked (typically every two years), grease that has accumulated in the retractable bow plane compartment is removed and disposed of in an approved manner by a qualified shore facility.<sup>1</sup>

Under normal operating conditions, little hydraulic oil is released within 12 n.m. of shore. Within this zone, the snorkel masts and the antennas are above the water line and do not contact seawater (except for an occasional sea spray). Hydraulic oil may be released when the external hydraulic systems are tested during outbound transits. Leaked oil, if any, is likely to be small quantities that adhere to the component surface. Only when the submarine submerges (beyond 12 n.m.) will the oil be washed away. Oil releases from bow planes generally remain in the upper area of the cavities surrounding the planes. Because of the small size, configuration, location of the bow plane cavity opening, and minimal seawater turbulence, transport of trapped oil to the sea is unlikely. Further, only 22 of the 94 submarines in service have hydraulically operated bow planes. The secondary propulsion motor is available as a backup option to maneuver close to port when needed. Typically, tugs are available for this purpose and the secondary propulsion motor is not used under normal operating circumstances.

### **2.3 Vessels Producing the Discharge**

All submarines have lubricated outboard equipment and external hydraulic systems. Because all submarines belong to the Navy, this discharge is not produced by vessels belonging to the Army, Air Force, U.S. Coast Guard, and the Military Sealift Command.

## **3.0 DISCHARGE CHARACTERISTICS**

This section contains qualitative and quantitative information that characterizes the discharge. Section 3.1 describes where the discharge occurs with respect to harbors and near-shore areas; Section 3.2 describes the rate of the discharge; Section 3.3 lists the constituents in the discharge; and Section 3.4 gives the concentrations of the constituents in the discharge.

### **3.1 Locality**

Outboard equipment grease can be discharged within 12 n.m. of shore. The amount is dependent on how much contact there is between the seawater and the greased components, and how fast the vessel is traveling. Most hydraulically operated outboard equipment does not contact seawater within 12 n.m. of shore because submarines usually run surfaced in this zone and the outboard equipment is mostly above the waterline. Submarine dive points are outside the 12 n.m. zone except for those dive points off the coast of the Hawaiian islands and Washington state.<sup>4,5</sup>

### 3.2 Rate

This discharge is the washout of oil and grease when lubricated components and components with hydraulic oil come in contact with flowing seawater.

**Grease.** A rough estimate of grease discharge can be made based on the total amount used. Each attack submarine (SSN) uses approximately 425 pounds of grease annually, while each missile submarine (SSBN) uses an estimated 800 pounds annually.<sup>2</sup> Approximately 81% of the submarine fleet are SSNs and 19% are SSBNs. On a weighted average basis, therefore, each submarine uses approximately 496 pounds of grease each year.

The grease is released primarily by the mechanical action of the seawater against the greased submarine components and, therefore, happens only when the submarine is underway. Each submarine enters and leaves port approximately six times per year.<sup>3,6</sup> A typical one-way trip through the 12 n.m. zone lasts approximately 4 hours; therefore, the total annual transit time through that zone is 48 hours per submarine ((6) (4) (2) = 48).<sup>6</sup> A submarine typically spends 6 months, or 183 days, moving in the water so transit time accounts for less than 1.1% of this total time at sea. Therefore, 1.1% of the total grease used can be assumed to be released during transits.<sup>3,4</sup> The resulting 1.1% of the 496 pounds of grease per vessel per year is equivalent to a discharge rate of approximately 5.5 pounds of grease for each vessel per year within 12 n.m.

**Hydraulic Oil.** Hydraulic oil is retained in the system by internal and external seals; the former prevents hydraulic oil from leaking into the submarine, while the latter prevents oil from leaking outside the hull. Because some leaks still occur, the Navy has established acceptable leak rates.<sup>7</sup> For newly installed seals, the specification allows “a slight wetting of the tailrod or other visible part of the sealing area.” In addition to the “slight wetting” qualitative criterion, the specification also provides a quantitative leak rate standard of one drop every 25 cycles for each inch (or fraction) of rod (length) or seal diameter. For example, a cylinder with a 2.25-inch diameter rotating tailrod would be allowed to leak at a rate of three drops every 25 cycles. A cycle is defined as moving from a fully retracted position to a fully extended position and back.<sup>7</sup>

The specification also contains seal replacement criteria. If leaks occur when a component is not operating, the seal should be replaced when the leak rate is four milliliters (mL) or more per hour for each inch (or fraction) of seal diameter. If leaks occur when a component is cycled, the seal should be replaced when a leak rate of one mL or more per inch of seal diameter (or fraction) for every 10 cycles is observed.

Leak rate standards can be used to estimate the amount of oil that leaks into the sea from external hydraulic systems seals. For example, the two bow planes, when deployed, are each 7.5 feet long. At a rate of one drop of oil every 25 cycles for each inch of rod length, the acceptable leak rate for the two diving planes, which are a combined 15 feet long, is 180 drops (15 feet = 180 inches) every 25 cycles. Assuming that 10 drops are equivalent to one mL,<sup>2</sup> 18 mL of oil will leak every 25 cycles. Therefore, each time the bow planes are extended and retracted (one cycle), approximately 0.72 mL (18 mL/ 25 cycles) of oil will be released but will likely remain in the bow plane cavity. Assuming six outbound transits per year for each vessel and that the vessel cycles its

retractable bow planes twice during each transit, this would result in a discharge rate of 8.64 mL of oil discharged per vessel per year. This calculation assumes that external hydraulic systems are tested during outbound transits only.

### **3.3 Constituents**

This discharge consists of Termalene #2 grease and hydraulic oil. Termalene #2 consists of mineral oil, a calcium-based rust inhibitor, an antioxidant, and dye.<sup>8</sup> Hydraulic oil consists of heavy paraffinic distillates and additives.

In general, greases are made from lubricating stocks generated during petroleum fractionation. These fractions contain organic compounds (C<sub>17</sub> or higher). Lubricating oils are composed of aliphatic, olefinic, naphthenic (cycloparaffinic), as well as aromatic hydrocarbons, depending on their specific use. Lubricating oil additives include antioxidants, bearing protectors, wear resisters, dispersants, detergents, viscosity index improvers, pourpoint depressors, and antifoaming and rust-resisting agents.<sup>9</sup> Lubricating oils and greases could have priority pollutants. No bioaccumulators are expected.

### **3.4 Concentrations**

The discharge consists of 100% grease and oil in their pure form as they are washed away from the vessel's surface due to mechanical action of water. Because the oil or grease do not become mixed with water until they contact the surrounding seawater, concentrations in the discharge cannot be defined in the conventional sense. It is known that the hydraulic oil consists of 95-99% heavy paraffinic distillates.<sup>10</sup> The remainder consists of additives.

## **4.0 NATURE OF DISCHARGE ANALYSIS**

Based on the discharge characteristics presented in Section 3.0, the nature of discharge and its potential impact on the environment can be evaluated. The estimated mass loadings are presented in Section 4.1. In Section 4.2, the concentrations of discharge constituents after release to the environment are estimated and compared with the water quality criteria. In Section 4.3, the potential for transfer of non-indigenous species is discussed.

### **4.1 Mass Loading**

#### **4.1.1 Grease From Outboard Equipment**

Using the assumption that 100% of the applied grease is washed away, the annual amount of grease discharged by each submarine within 12 n.m. is 1.1% of the total grease used (Section 3.2), or approximately 5.5 pounds per vessel per year. Based on 94 submarines, the total amount of grease discharged within 12 n.m. on an annual basis is 517 pounds.

### 4.1.2 External Hydraulics

Based on a per vessel discharge rate of 1.44 mL per vessel per transit (six transits per vessel per year) or 8.64 mL per vessel per year and given that there are 22 submarines currently existing in the fleet that contribute to this discharge, the fleet wide mass loading is 190 mL per year. This is equivalent to 0.0029 pound (lb) per vessel per transit (at a density of 7.51 lb/gallon) or 0.3755 lb of oil released per year by the entire submarine fleet.

## 4.2 Environmental Concentrations

As a submarine moves, it creates a disturbance in the surrounding seawater. This disturbed volume of seawater may be thought of as a mixing zone in which discharges from the submarine would be dispersed. This volume of seawater was estimated and used in concentration calculations. A sample calculation for a SSN 688 Class submarine is presented below. The calculation was based on the following assumptions:

- SSN 688 Class submarine has a total width of 33 feet.<sup>11</sup>
- Width is the diameter of the vessel's cross section.
- A mixing zone of 10 feet around the hull, based on the width of wake behind a typical SSN.
- The discharge is mixed uniformly throughout the mixing zone over the entire transit.
- The submarine is only partially submerged, at an approximate depth of 28 feet

1) Cross-sectional area = (area of submarine cross section and disturbed width) - (area of the chord representing that portion of the circle above the surface of the water)  
area =  $[(3.14) (33/2 + 10)^2] - [\text{area of a chord of height 15 ft of a circle of radius 26.5 ft}]$   
area =  $2,206 \text{ ft}^2 - 514 \text{ ft}^2 = 1692 \text{ ft}^2$

2) Volume of water swept = (area) (12 n.m. distance)  
volume =  $(1,692 \text{ ft}^2) (72, 960 \text{ ft}) = 1.23 \times 10^8 \text{ ft}^3$ , or **123 million cubic feet**

The width of submarines ranges from 31.8 feet (SSN 637 Class) to 42.3 feet (SSN 21 Class).<sup>11</sup> Therefore, the range of volume of water swept, using similar calculations to those above, would be 118 million cubic feet to 158 million cubic feet per submarine per transit.

### 4.2.1 Grease from Outboard Equipment

To develop environmental concentration estimates for grease, it is assumed that the 5 pounds of grease discharged per year are evenly distributed over the 12 transits through the 12 n.m. zone. Therefore, for each transit, approximately 0.46 pound (5.5 pounds of grease per submarine per year divided by 12 transits per year) of grease is discharged. Based on the previous calculations, the smallest volume of water swept by a submarine is 118 million cubic feet by the SSN 637 Class. Therefore, the concentration in the environment was estimated as presented

below: (Note: The calculations were based on the area swept by the SSN 637 class hull as it represents the smallest swept area.)

$$\begin{aligned} & 0.46 \text{ pound of grease} \div 1.18 \times 10^8 \text{ ft}^3 \text{ of water} \\ & = 208.6 \text{ g of grease in } 3.34 \times 10^9 \text{ Liters of water} \\ & = \mathbf{6.2 \times 10^{-8} \text{ g/L} = 0.062 \text{ } \mu\text{g/L}} \end{aligned}$$

This estimated concentration was based on 100% of the grease being washed away. Most grease discharged remains in hull cavities and is removed from the submarine during maintenance. Although open to seawater, the 0.5-inch-wide gaps around retractable bow planes are well shielded by close-fitting brushes, and the seawater in the compartment or cavity is quiescent compared to water moving over the hull. Therefore, the rate of grease erosion will be lower than the amount calculated.

#### 4.2.2 External Hydraulics

To estimate environmental concentrations for hydraulic oil, the following assumptions are made:

- Volume of water swept by the submarine is 118 million ft<sup>3</sup> or 3.34 x 10<sup>9</sup> liters per transit.
- The discharge rate of hydraulic oil is 0.0029 lb per vessel per transit uniformly distributed throughout the transit.

Based on the above assumptions, the environmental concentration can be estimated as follows:

$$\begin{aligned} 1) \text{ Oil released} &= 0.0029 \text{ lbs} = 1.32 \text{ g of oil released per vessel per transit} \\ 2) \text{ Concentration} &= (\text{g of oil released}) \div (\text{liters of water}) \\ &= (1.32 \text{ g}) \div (3.34 \times 10^9 \text{ L}) \\ &= \mathbf{3.95 \times 10^{-10} \text{ g/L} = 3.95 \times 10^{-4} \text{ } \mu\text{g/L}} \end{aligned}$$

#### 4.2.3 Total Releases

Based on the environmental concentrations estimated above, the total oil & grease concentration in the surrounding water would be the sum of individual concentrations, i.e., 0.062  $\mu\text{g/L}$  + 0.000395  $\mu\text{g/L}$  = 0.062395  $\mu\text{g/L}$ , or approximately 0.06  $\mu\text{g/L}$ . This concentration does not exceed federal discharge standards and state water quality criteria as shown in Table 1.

#### 4.3 Potential for Introducing Non-Indigenous Species

Non-indigenous species are not introduced by this discharge because seawater is not taken aboard or discharged when this discharge is generated.

## 5.0 CONCLUSIONS

The submarine outboard equipment grease and external hydraulics system discharge has a low potential to cause an adverse environmental effect. This is due to the small amounts of lubricant released when the vessel is underway is dispersed to concentrations below water quality criteria. The estimated concentrations of oil and grease in the environment that results from movement of submarines, is 0.06 ppb, which is far below Federal and most stringent state water quality criteria. These concentrations were estimated based on the volume of water (3.3 billion liters) swept by a submarine while in transit through the 12 n.m. zone, and the conservatively estimated amount of oil and grease released during transit (1.44 mL and 0.46 pounds, respectively).

## 6.0 DATA SOURCES AND REFERENCES

To characterize this discharge, information from various sources was obtained. Process information and assumptions were used to estimate the rate of discharge. Based on this estimate and on the reported concentrations of oil and grease components, the concentrations of oil and grease in the environment resulting from this discharge were then estimated. Table 2 shows the sources of the data used to develop this NOD report.

### Specific References

1. UNDS Equipment Expert Meeting, Submarine Outboard Equipment Grease. September 1, 1996.
2. UNDS Round 2 Equipment Expert Meeting Minutes, March 24, 1997.
3. Personal Communication between Commander, Submarine Forces, Atlantic Fleet, Staff Environmental Officer, LCDR L. McFarland and Bruce Miller, MR&S. April 28, 1997.
4. Commander, Submarine Forces, Atlantic Fleet, Staff Environmental Officer, LCDR L. McFarland. CINCLANTFLT meeting with SEA 00T/03L, May 13, 1997.
5. Personal Communication between Commander, Submarine Forces Pacific Fleet, Staff Environmental Officer, LCDR W. Jederberg and Bruce Miller, MR&S, Sept 11, 1997.
6. Pentagon Ship Movement Data for Years 1991-95, March 4, 1997.
7. Naval Ship's Technical Manual (NSTM), Chapter 556, Revision 2, Hydraulic Equipment Power Transmission and Control. pp 11-1 and 11-2. March 1, 1993.
8. Bel-Ray Company, Inc., Material Safety Data Sheet for Termalene #2, May 5, 1998.

9. Patty's Industrial Hygiene and Toxicology, Volume IIB, 3rd Revised Edition, 1981, pp 3369, 3397.
10. Material Safety Data Sheet, Imperial 2075 TH Petroleum Base Hydraulic Fluid, January 1998.
11. Jane's Information Group, Jane's Fighting Ships. Capt. Richard Sharpe, Ed. Sentinel House: Surrey, United Kingdom, 1996.

### **General References**

USEPA. Toxics Criteria for Those States Not Complying with Clean Water Act Section 303(c)(2)(B). 40 CFR Part 131.36.

USEPA. Interim Final Rule. Water Quality Standards; Establishment of Numeric Criteria for Priority Toxic Pollutants; States' Compliance – Revision of Metals Criteria. 60 FR 22230. May 4, 1995.

USEPA. Water Quality Standards; Establishment of Numeric Criteria for Priority Toxic Pollutants. 57 FR 60848. December 22, 1992.

USEPA. Water Quality Standards; Establishment of Numeric Criteria for Priority Toxic Pollutants for the State of California, Proposed Rule under 40 CFR Part 131, Federal Register, Vol. 62, Number 150. August 5, 1997.

Connecticut. Department of Environmental Protection. Water Quality Standards. Surface Water Quality Standards Effective April 8, 1997.

Florida. Department of Environmental Protection. Surface Water Quality Standards, Chapter 62-302. Effective December 26, 1996.

Georgia Final Regulations. Chapter 391-3-6, Water Quality Control, as provided by The Bureau of National Affairs, Inc., 1996.

Hawaii. Hawaiian Water Quality Standards. Section 11, Chapter 54 of the State Code.

Mississippi. Water Quality Criteria for Intrastate, Interstate and Coastal Waters. Mississippi Department of Environmental Quality, Office of Pollution Control. Adopted November 16, 1995.

New Jersey Final Regulations. Surface Water Quality Standards, Section 7:9B-1, as provided by The Bureau of National Affairs, Inc., 1996.

Texas. Texas Surface Water Quality Standards, Sections 307.2 - 307.10. Texas Natural Resource Conservation Commission. Effective July 13, 1995.

Virginia. Water Quality Standards. Chapter 260, Virginia Administrative Code (VAC) , 9 VAC 25-260.

Washington. Water Quality Standards for Surface Waters of the State of Washington. Chapter 173-201A, Washington Administrative Code (WAC).

Committee Print Number 95-30 of the Committee on Public Works and Transportation of the House of Representatives, Table 1.

The Water Quality Guidance for the Great Lakes System, Table 6A. Volume 60 Federal Register, p. 15366. 23 March 1995.

**Table 1. Comparison of Environmental Concentration with Relevant Water Quality Criteria**

| Constituent  | Concentration | Federal Discharge Standard                            | Florida Acute Water Quality Criteria |
|--------------|---------------|---|--------------------------------------|
| Oil & Grease | 6 µg/L        | visible sheen <sup>a</sup> / 15,000 µg/L <sup>b</sup> | 5,000 µg/L                           |

Refer to federal criteria promulgated by EPA in its National Toxics Rule, 40 CFR 131.36 (57 FR 60848; Dec. 22, 1992 and 60 FR 22230; May 4, 1995)

<sup>a</sup> *Discharge of Oil*, 40 CFR 110, defines a prohibited discharge of oil as any discharge sufficient to cause a sheen on receiving waters.

<sup>b</sup> *International Convention for the Prevention of Pollution from Ships* (MARPOL 73/78). MARPOL 73/78 as implemented by the *Act to Prevent Pollution from Ships* (APPS)

**Table 2. Data Sources**

| NOD Section  | Data Source   |          |           |                  |
|--|---------------|----------|-----------|------------------|
|  | Reported      | Sampling | Estimated | Equipment Expert |
| 2.1 Equipment Description and Operation              |               |          |           | X                |
| 2.2 Releases to the Environment                      |               |          |           | X                |
| 2.3 Vessels Producing the Discharge                  | UNDS Database |          |           | X                |
| 3.1 Locality   |               |          |           | X                |
| 3.2 Rate   |               |          | X         |                  |
| 3.3 Constituents                                     |               |          |           | X                |
| 3.4 Concentrations                                   | X             |          |           | X                |
| 4.1 Mass Loadings                                    |               |          | X         |                  |
| 4.2 Environmental Concentrations                     | X             |          | X         |                  |
| 4.3 Potential for Introducing Non-Indigenous Species |               |          | X         | X                |



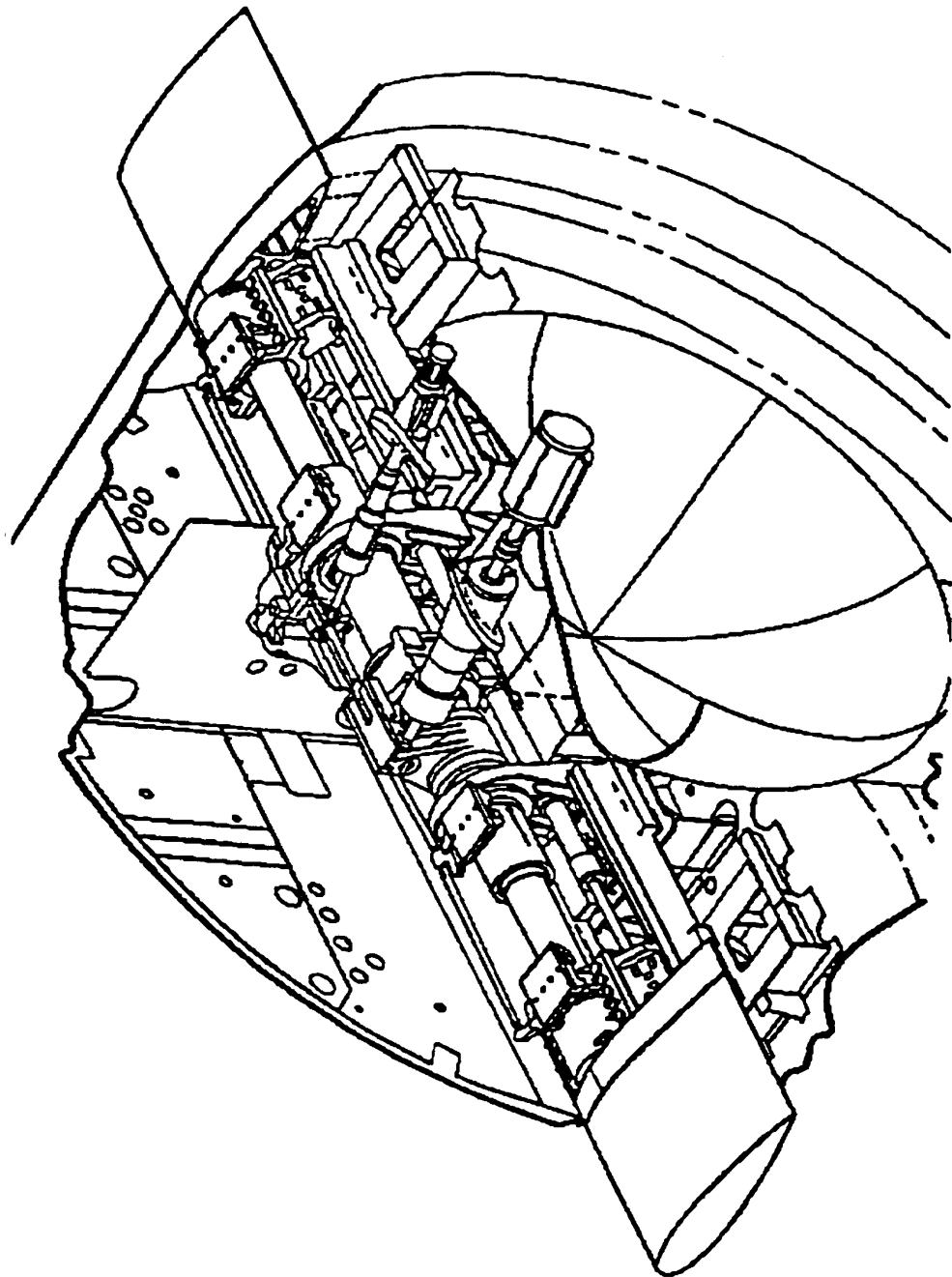

**Figure 2. Retractable Bow Plane Arrangement (Typical)**

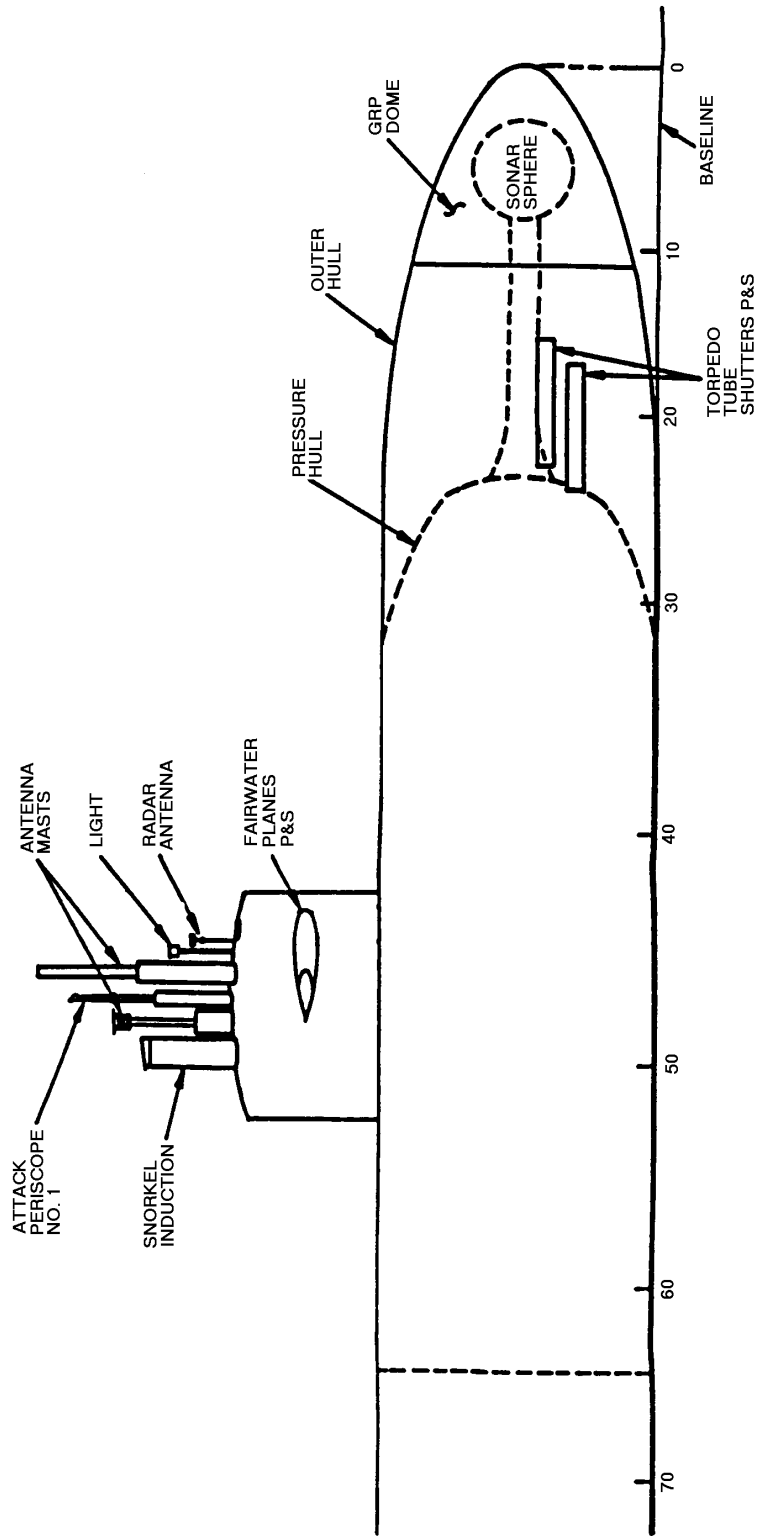

**Figure 3. Location of Masts, Antennas, and Periscopes**